

GO SILENTLY
AT HIGH PRESSURE
& HIGH SPEED



Patents approved
Brevetti approvati



INDUSTRIAL



MOBILE



MARINE

CONTINUUM[®] PUMP series

Helical rotors pumps for high pressure
and no noise application

The new generation of gear pumps for
NO PULSATION & NO NOISE

Achieves better efficiency, lower production cost, better life quality for the industrial world.
Ottiene alti livelli di efficienza , ridotti costi di produzione ed una migliore qualità del lavoro.

Reducing noise in the workplace has become a necessity for many companies. By now most companies have recognized noise as a cost weighting on the economics of their businesses. Noise pollution remains a serious problem to be solved for both stationary and mobile machinery. Hydraulic pumps, above all those for high pressure, entail unacceptable noise and/or vibration levels in many different applications.

Up to now the noise problem has always been approached in the only possible way: with secondary and expensive activities such as using pulsation dampers, hoses, damping rails and rings, encapsulating the hydraulic components or the entire system and so on.

SETTIMA decided to start to design a new gear pumps generation capable to reduce as much as possible the acoustic emissions and the consequent vibration level. Some years ago the result was the **Continuum® pump series**, able to reduce down to 52 dB(A) the normal operation noise.

Today SETTIMA presents the new generation of **Continuum® pumps**, silent as always, but much more efficient and with longer lifetime even at heavy duty, at all pressure and speed ranges.

The most important economic benefits of using **Continuum® pumps** are:

- very low pump pulsations reduce dramatically also vibrations with no dispersion of energy,
- saving money respect to the more expensive traditional pumps such as piston pumps and internal gear pumps,
- high volumetric efficiency, also at very low speed, contributes to cost reduction and also enables the pump to be driven by motor at a variable velocity with consequent energy saving,
- cost saving by eliminating second noise reduction measures,
- keeping the same external dimensions of gear pump, with no necessity to redesign the system in case of replacement.

COMPETITIVE ANALYSIS

Continuum® pump is a valid alternative to silently replace different traditional solutions of noisy high pressure pump.

Continuum® pump can replace the following types of high pressure pump:

- External gear pumps
- Internal gear pumps
- Fixed displacement vane pumps
- Fixed displacement piston pumps

Please contact Settima for all information about any possible replacement.

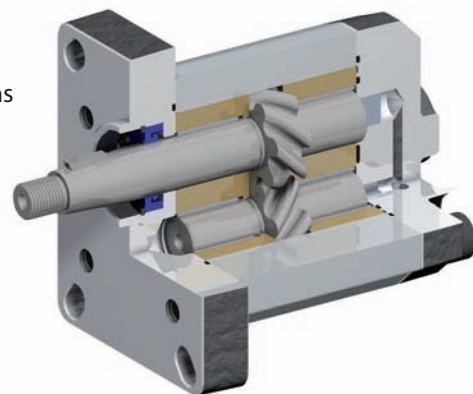

ORIGIN OF NOISE AND VIBRATIONS KNOCKED DOWN BY CONTINUUM® PUMP

LA POMPA CONTINUUM® HA ELIMINATO LE ORIGINI DEL RUMORE E DELLE VIBRAZIONI

The typical sound emissions of gear pumps have two distinct origins: mechanical noise and hydraulic noise. The mechanical noise is what can be expected from any pair of gears. The hydraulic noise, however, is generated by the perturbations of fluid pressure through the pump. This noise and/or vibration comes from three basic components:

- cavitation, that can cause serious noise in addition to structural damage to mechanical components
- the peak pressure that arises from trapping of fluid between the top and the bottom of the tooth,
- the "ripple" or the flow pulsation during meshing that causes pressure pulsation.

The continuous contact helical rotor **Continuum® pump** has solved these problems with sophisticated and efficient systems.

THINK DIFFERENT: THE SILENT AND UNIQUE REVOLUTION OF CONTINUUM® PUMP

UNA RIVOLUZIONE SILENZIOSA: LA POMPA CONTINUUM®

As for classic gear pumps, the transport flow is perpendicular to the axes, but the rotors profile, specially developed and internationally patented, does not trap any volume since the helical design of the profile plays the role of completing an overlap, making a gentle transmission of fluid resulting in a dramatic reduction of pulsation. There is just a single point of contact between the profiles

during rotation, which eliminates the pockets acting on the axial thrust washer and the noise associated with this problem.

The Continuum® core and its technological innovation is based on three patented breakthroughs:

- The rotor profile
- The screw step
- The inner force balancing.



MANUFACTURING ACCURACY IN ANY DETAILS

MASSIMA ACCURATEZZA NEI DETTAGLI

SETTIMA produces hydraulic pumps since over thirty years, achieving a high level of competence and accuracy in the manufacture of high-precision pump drives. Together with top production machineries, efficient test environments, 3D drawing capability and special materials for rotors and bushings, **SETTIMA** constantly achieves products of high quality that is the industry standard.

CONTINUUM® PUMP ADVANTAGES

VANTAGGI DELLA POMPA CONTINUUM®

- Low noise also at high speed (up to 6.500 RPM).
- Average of 15 db(A) less noisy than standard external gear pumps.
- Reduced noise level for the machine operator and surroundings.
- Cost saving by eliminating second noise reduction measures.
- Easy to replace thanks to compatibility with all external gear pumps.
- Helps meet legal noise requirements.
- Continuous variable flow rate (0% to 100%).
- Unidirectional pump and/or bi-directional pump/motor.
- Intermittent operation at high pressure & low speed.
- Allowed to be driven by servo motors or asynchronous motors.
- High volumetrical efficiency.
- Fast reverse RPM allowed: CCW max < 400.
- Response time < 100 ms due to very small internal mechanical inertia.



Environment: 100bar - 40 cSt - 1.500 rpm

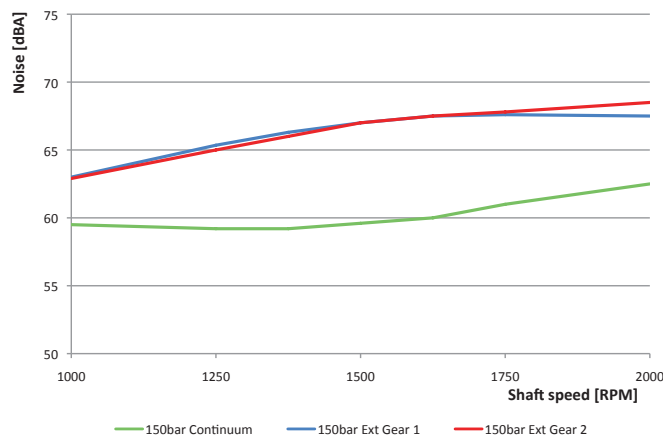
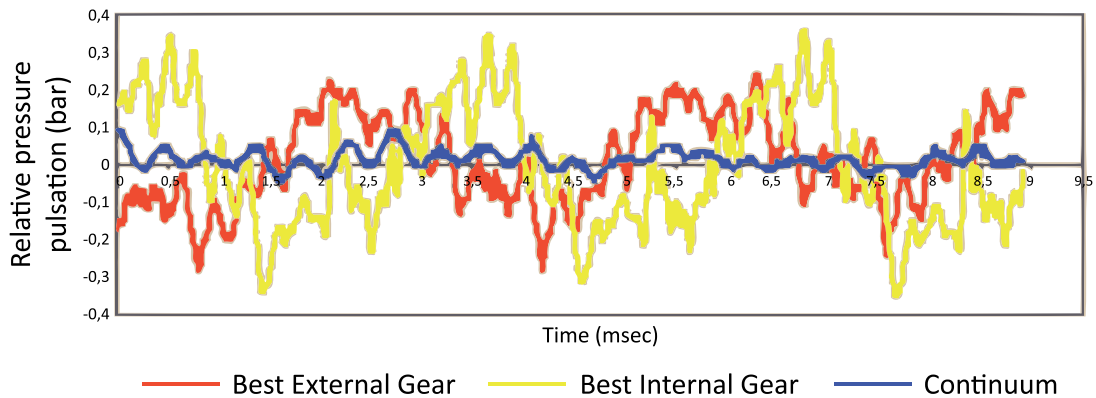

INDUSTRIAL

Machine tools lubrication systems.

Lifting equipment, hydraulic systems for dock-levelers.

Hydraulic transmission systems.

Machines lubrication.

Chemical metering.

Hydraulic systems for injection moulding machines, presses, compactors and balers.

Systems for lubrication and cooling of gearboxes and bearings.

Hydraulic powerpack.

Hydro power.

Feeder system for filter circuits, cooling circuits, lubrication applications, pump transfer unit.

MOBILE

Ground-handling equipment.

Agricultural machinery.

Hydraulic systems for parking systems.

Steering units.

Torque converters & power-shift transmissions.

Street-sweeping vehicles.

Shredder systems.

Waste container level lifter.

ENVIRONMENTAL INDUSTRY

Baler and compacting of waste.

Containers.

Hooklift containers.

Back loading containers.

Front loading containers.

Liftdumper containers.

Hooklift systems.

Garbage trucks.

Mobile compactors.

Stationary compactors.

MARINE

Marine power hydraulics.

Rudder actuators (tandem system).

Propeller pitch control.

Propeller drive (power transmission from engine).

Rotary vane steering gears.

Minipowerpacks (dock operation, door control).

Yacht building industry (lifting systems: fly bridge cranes, tenderlift, elevator, walkways, automatic swimming ladders, side boarding ladders, pitch controls and operations, hydraulic davits).



Technical characteristics / Caratteristiche tecniche

SPECIAL HELICAL ROTORS – CONTINUUM® represents an innovative and revolutionary gear pump. The patented profile of the **Continuum®** rotors permits just a single point of contact between gears: this results, together with a particular screw step and inner force balancing, in the total absence of trapped and compressed oil, and leads to no noise and no pulsation.

HIGH PRESSURE – CONTINUUM® has been designed for high pressure, high speed and heavy duty.

TANDEM GROUP – CONTINUUM® can be also assembled as a double pump, connecting two pumps from different groups: from group 1 to group 4.

Technical characteristics

Models Modelli	28 - 33 - 38 - 47 - 55 - 72 - 92* - 106*		
Flanges Flange	Group 1 – Group 2 (European, German, BKT, SAE-A) – Group 3 (European, SAE-B) – Group 4 (SAE-D) <i>Gruppo 1 – Gruppo 2 (Europeo, Tedesco, BKT, SAE-A) – Gruppo 3 (Europeo, SAE-B) – Gruppo 4 (SAE-D)</i>		
Connections Conessioni	BSPP (GAS) – SAE 3000/6000 PSI – FL 4 HOLES M6 SU Ø40 DN20 (mentioned connections depend on model) <i>BSPP (GAS) – SAE 3000/6000 PSI – FL 4 HOLES M6 SU Ø40 DN20 (in base al modello)</i>		
Installation position Posizione di installazione	External and/or under oil <i>Esterna e/o immersa</i>		
Shaft rotation Rotazione	Clockwise (please contact Settima for counter clockwise) <i>Destra (contattare Settima per sinistra)</i>		
Shaft speed Velocità di rotazione	From 150 to 6.500 rpm (for usage below 1.000 rpm or over 1.800 rpm please contact Settima) <i>Da 150 a 6.500 rpm (per utilizzi a giri inferiori a 1.000 rpm o superiori a 1.800 rpm contattare Settima)</i>		
Flows Portate	From 4 up to 220 cm ³ – from 6L/min up to 330L/min (at 1.500 rpm) <i>Da 4 fino a 220 cm³ – da 6L/min fino a 330L/min (a 1.500 rpm)</i>		
Operating pressure Pressione operativa	Max. Continuous: 275 bar Max. Cycle ON/OFF: 280 bar Max. Peak: 300 bar	Depending on models Depending on models Depending on models	<i>Max. Continuo: 275 bar Max. Ciclo ON/OFF: 280 bar Max. Picco: 300 bar</i> <i>In base al modello In base al modello In base al modello</i>
Inlet pressure Pressione di aspirazione	0,8 – 3 bar (depends on models) 0,8 – 3 bar (in base al modello)		
Fluids Fluidi	- Mineral oil - Synthetic oil	- <i>Olio minerale</i> - <i>Olio sintetico</i>	
Viscosity* Viscosità*	Possible: from 5 up to 800 cSt** Recommended: from 32 up to 150 cSt Starting condition: up to 3.000 cSt**	<i>Consentita: da 5 fino a 800 cSt** Raccomandata: da 32 fino a 150 cSt Condizioni di avviamento: fino a 3.000 cSt**</i>	
Environmental temperature Temperatura ambiente	From -15°C up to +60°C <i>Da -15°C a +60°C</i>		
Oil temperature Temperatura olio	From -15°C up to +80°C <i>Da -15°C a +80°C</i>		
Contamination level Livello di contaminazione	Up to 8 NAS (18/17/14 ISO4406) (for heavy duty operations over 150 bar, over 4 working hours/day, 100 cycle/day oil ISO 46) <i>Fino a 8 NAS (18/17/14 ISO4406) (per lavoro ad alto sforzo oltre 150 bar, oltre 4 ore lavorative/giorno, 100 cicli/giorno olio ISO 46)</i>		
Filtration Filtrazione	From 25 to 10 µm (for heavy duty operations over 150 bar, over 4 working hours/day, 100 cycle/day oil ISO 46) <i>Da 25 a 10 µm (per lavoro ad alto sforzo oltre 150 bar, oltre 4 ore lavorative/giorno, 100 cicli/giorno olio ISO 46)</i>		
Seals Guarnizioni	NBR, FKM (others on request) <i>NBR, FKM (altri a richiesta)</i>		
Acoustic emissions Emissioni acustiche	From 52 up to 63 db(A) at 2.950 rpm <i>Da 52 fino a 63 db(A) at 2.950 rpm</i>		
Flanges material Materiale delle flange	Cast iron <i>Ghisa</i>		
Pump body Corpo	Extruded aluminium alloy <i>Alluminio estruso</i>		
Screws Viti	Hardened steel <i>Acciaio temprato</i>		

* Model GR92 and GR106 will be available soon. I modelli GR92 e GR106 saranno disponibili a breve.

** Please for more information about possible and starting conditions of viscosity contact Settima. Contattare Settima per maggiori informazioni sui livelli di viscosità possibili e quelli delle condizioni di inizio lavoro.

Product description / Descrizione prodotto

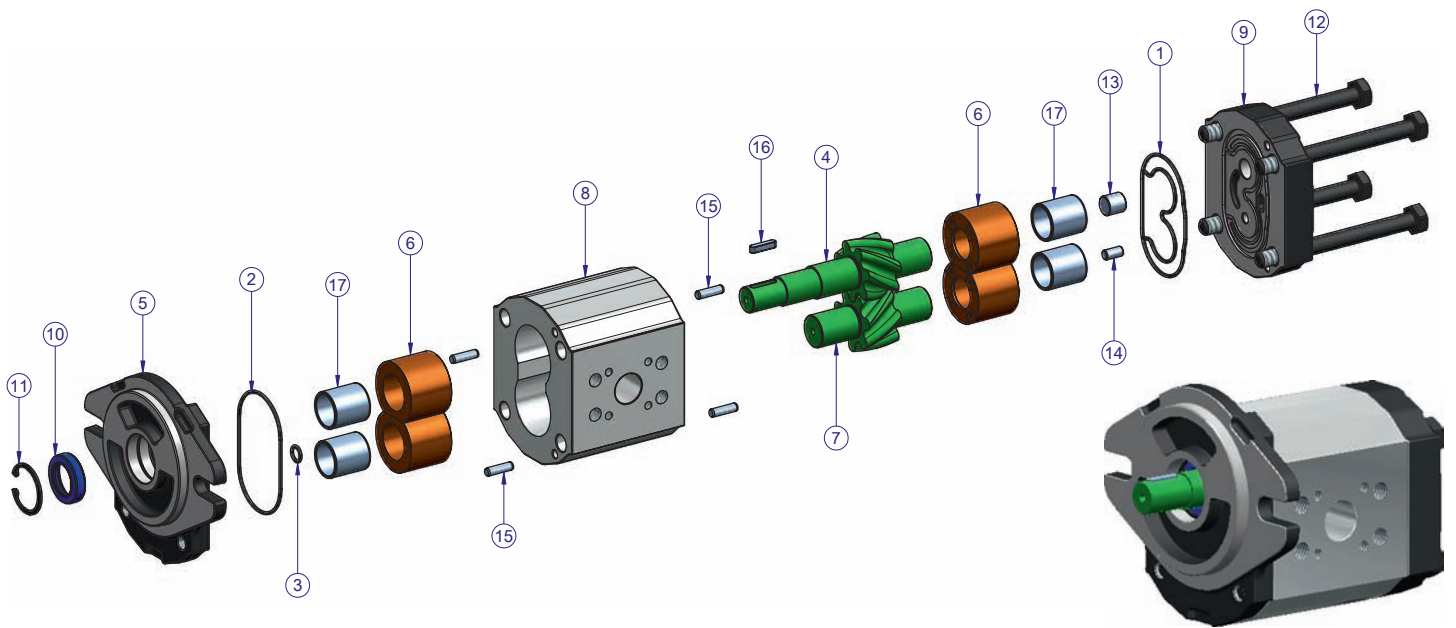

N°	DESCRIPTION/DESCRIZIONE	MATERIAL / MATERIALE
1	O-ring seal / O-ring	NBR
2	O-ring seal / O-ring	NBR
3	O-ring seal / O-ring	NBR
4	Driving Continuum® rotor / Rotore guida Continuum®	Hardened steel / Acciaio temprato
5	Motor flange / Flangia motore	Cast iron / Ghisa
6	Ring for bush / Anello porta boccia	Bronze / Bronzo
7	Driven Continuum® rotor / Rotore guidato Continuum®	Hardened steel / Acciaio temprato
8	Body / Corpo	Extruded aluminum alloy / Alluminio estruso
9	Cover flange / Flangia	Cast iron / Ghisa
10	Seal / Anello di tenuta	NBR
11	Seeger / Seeger	Steel / Acciaio
12	Screws / Viti di fissaggio	Steel / Acciaio
13	Piston / Pistone	Steel / Acciaio
14	Piston / Pistone	Steel / Acciaio
15	Centring Keys / Spine di centraggio	Steel / Acciaio
17	Bushings / Bronzine	Steel with PTFE coating / Acciaio con rivestimento PTFE

Standard type and options

	STANDARD	OPTIONS
Pump Body	Alluminium	Cast iron
Seal kit	NBR	FKM

Single pump / Pompa singola

Type <i>Tipo</i>	Class <i>Classe</i>	Displacement <i>Cilindrata</i>	Flange & shaft <i>Flangia & albero</i>	Ports <i>Porte</i>	Shaft seal <i>Guarnizione albero</i>	Rotation <i>Rotazione</i>
GR28	2V	004-006-008-010-013	F1AC3-F1PAC2-F1KAG54-F1LAGL54- FSAEAAAC-F1KAGL54	G	Standard NBR (none)	Standard DX (none)
GR33	2V	010-013-015-018	F2AC4-F2BK7AG-FSAEAAAC-FSAEAAT9	G-M		
GR38	2V	016-018-020-022-025-028	F2AC4-F2BK7AG-FSAEAAAC- FSAEAAT11-FSAEAAT9	G-M		
GR47	2V	028-032-036-040-045-050	F3AC9-FSAEBAC-FSAEBAT13	O	Optional FKM V	Optional
GR55	2V	050-063-075-090	FSAEBAC-FSAEBAT15	O-OE		
GR72	2V	094-101-125-150-175-200-220	FSAEDAC-FSAEDAT23	ME		

* Please Contact Settima for SX counter clockwise optional rotation.
Contattare Settima per rotazione SX opzionale.

DIRECTION OF ROTATION / SENSO DI ROTAZIONE

Continuum® pumps are available with right rotation as standard configuration and left rotation as optional configuration. Right hand rotation means that, when standing in front of the pump, with driving shaft towards to the observer, the pump is rotating clockwise (DX). The other way around with left hand rotation, counter clockwise (SX).

*Le pompe **Continuum**® sono fornite con la configurazione standard di rotazione destra. Opzionale la rotazione sinistra. Con rotazione destra (DX) si intende che, guardando la pompa frontalmente, con l'albero conduttore sporgente verso il punto di osservazione, la rotazione sarà in senso orario, con il lato mandata sulla destra e il lato aspirazione sulla sinistra della pompa. Viceversa per quanto riguarda la rotazione sinistra (SX).*

Continuum® pumps, despite the type of configuration, can rotate to the opposite side if the pressure is not higher than 10% of maximum continuous pressure (check the Technical Characteristics table).

*Le pompe **Continuum**®, qualunque configurazione di rotazione abbiano, possono ruotare in senso inverso a pressioni non superiore al 10% della massima pressione continua (verificare nella tabella delle caratteristiche tecniche).*

DX: Clockwise rotation / Rotazione destra

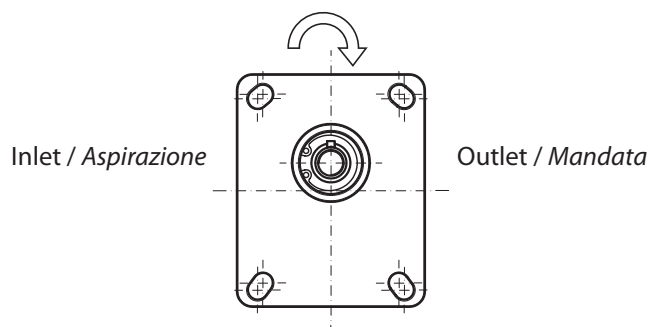

SX: Counter clockwise rotation / Rotazione sinistra

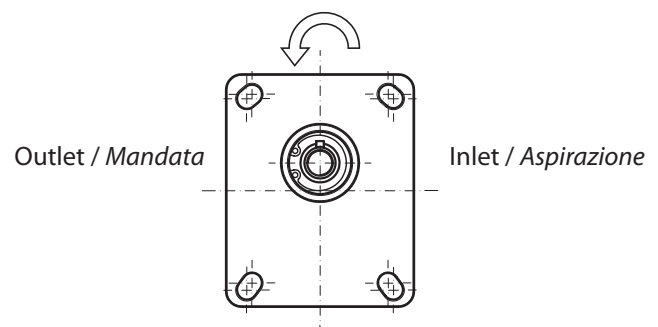

SHAFT AND FLANGE TYPE AND DIMENSIONS / TIPO ALBERO E FLANGE E DIMENSIONI

Group 1 pumps / Pompe gruppo 1

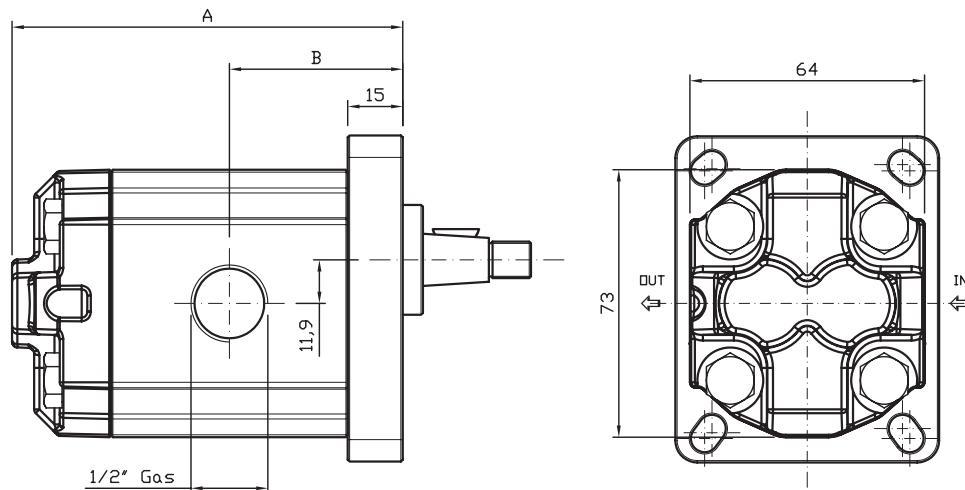

Available flanges and shafts / Flange ed alberi disponibili

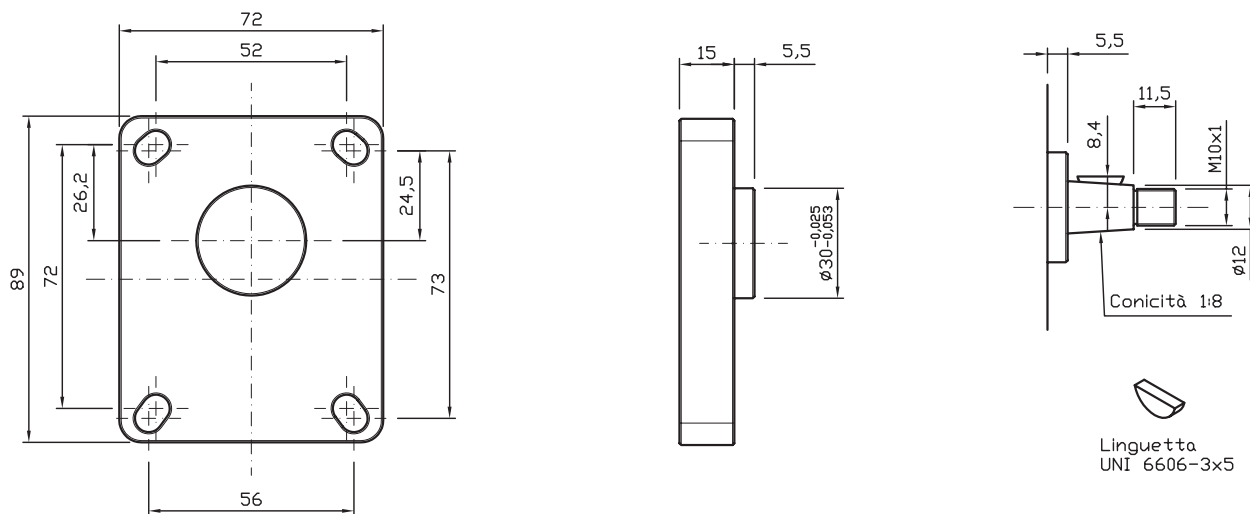

TYPE / TIPO 1-C3

Type Tipo	CC	L/min	Dimensions A Dimensioni A	Dimensions B Dimensioni B	Continuous Pressure Pressione continua	Intermittent Pressure Pressione intermittente (*)	Peak pressure Picco pressione (*)	Noise level Livello rumore
4	4,2	6,0	101,0	44,50	275	280	300	55
6	6,4	9,2	106,5	47,25	275	280	300	55
8	8,3	12,0	111,5	49,75	246	260	280	55
10	10,2	14,7	116,5	52,25	222	250	270	55
13	12,9	18,6	123,4	55,55	176	230	250	55

Max torque / Coppia max: 100 Nm

* Intermittent: cycle 20 sec. ON & 3 sec. OFF - Peak: cycle 1 sec. ON & 3 sec OFF. Intermittente: ciclo 20 sec. ON & 3 sec. OFF - Picco: ciclo 1 sec. ON & 3 sec OFF

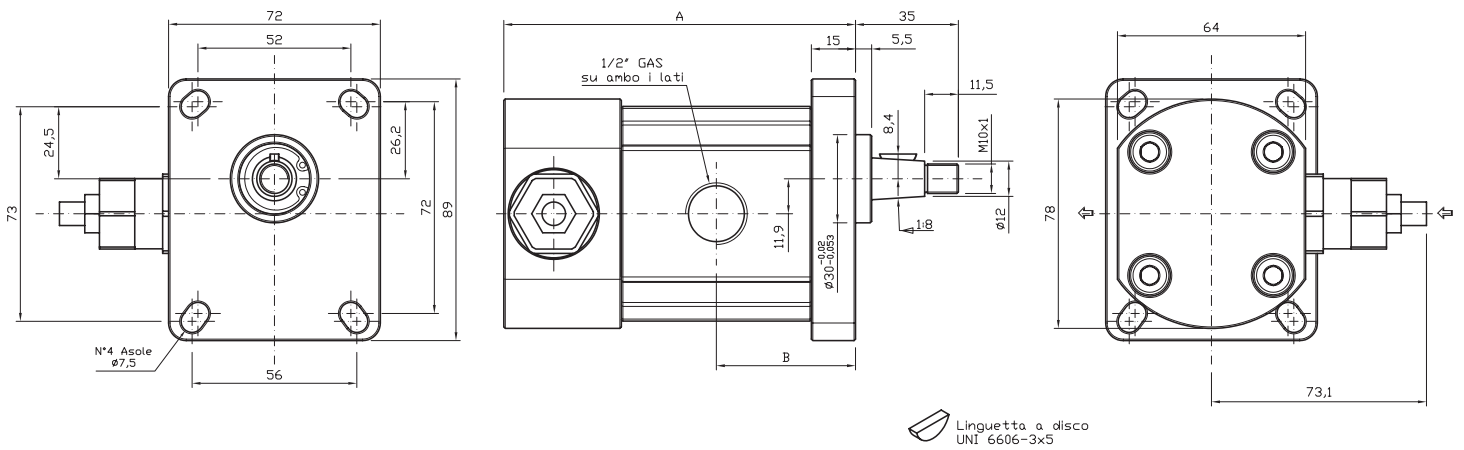

Linguetta a disco
UNI 6606-3x5

TYPE / TIPO 1-C3 (with safety valve/con valvola di massima)

Type Tipo	CC	L/min	Dimensions A Dimensioni A	Dimensions B Dimensioni B	Continuous Pressure Pressione continua	Intermittent Pressure Pressione intermittente (*)	Peak pressure Picco pressione (*)	Noise level Livello rumore
4	4,2	6,0	114,1	44,50	275	280	300	55
6	6,4	9,2	119,5	47,25	275	280	300	55
8	8,3	12,0	124,5	49,75	246	260	280	55
10	10,2	14,7	129,5	52,25	222	250	270	55
13	12,9	18,6	136,4	55,70	176	230	250	55

Max torque / Coppia max: 100 Nm

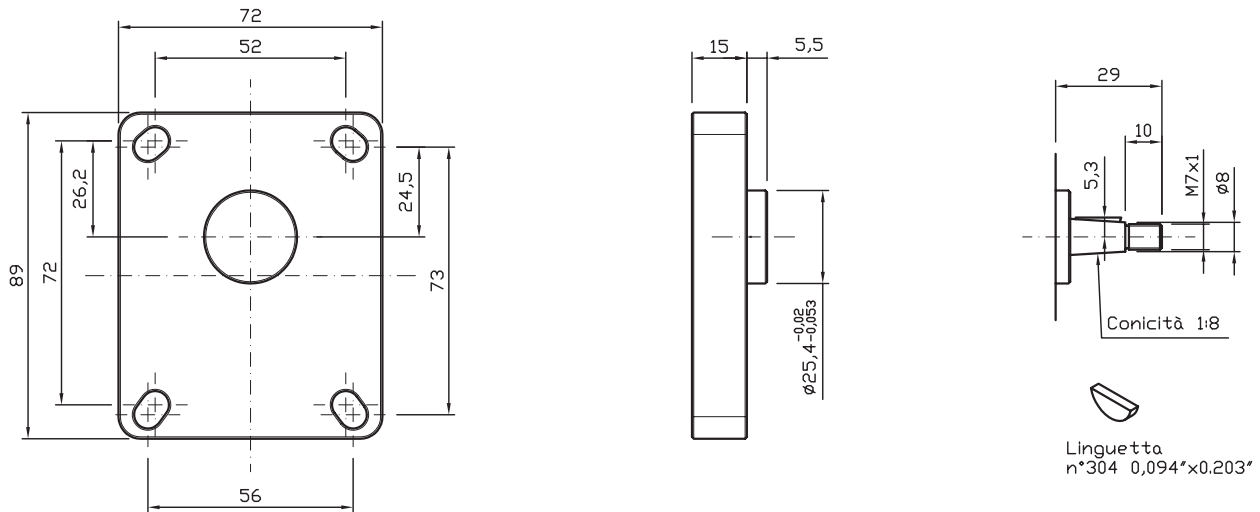

TYPE / TIPO 1P-C2

Type Tipo	CC	L/min	Dimensions A Dimensioni A	Dimensions B Dimensioni B	Continuous Pressure Pressione continua	Intermittent Pressure Pressione intermittente (*)	Peak pressure Picco pressione (*)	Noise level Livello rumore
4	4,2	6,0	101,0	44,50	240	260	280	55
6	6,4	9,2	106,5	47,25	230	240	270	55
8	8,3	12,0	111,5	49,75	200	210	220	55
10	10,2	14,7	116,5	52,25	160	170	180	55
13	12,9	18,6	123,4	55,70	140	150	160	55

Max torque / Coppia max: 50 Nm

* Intermittent: cycle 20 sec. ON & 3 sec. OFF - Peak: cycle 1 sec. ON & 3 sec OFF. Intermittente: ciclo 20 sec. ON & 3 sec. OFF - Picco: ciclo 1 sec. ON & 3 sec OFF

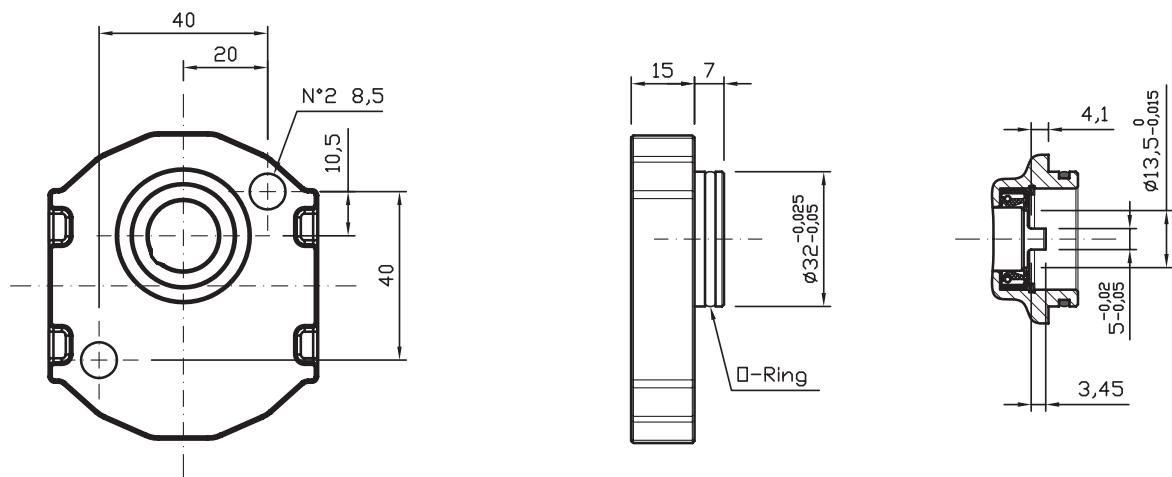

TYPE / TIPO 1K-G54

Type Tipo	CC	L/min	Dimensions A Dimensioni A	Dimensions B Dimensioni B	Continuous Pressure Pressione continua	Intermittent Pressure Pressione intermittente (*)	Peak pressure Picco pressione (*)	Noise level Livello rumore
4	4,2	6,0	101,0	44,50	275	280	300	55
6	6,4	9,2	106,5	47,25	230	240	270	55
8	8,3	12,0	111,5	49,75	180	200	210	55
10	10,2	14,7	116,5	52,25	150	160	170	55
13	12,9	18,6	123,4	55,70	120	130	140	55

Max torque / Coppia max: 40 Nm

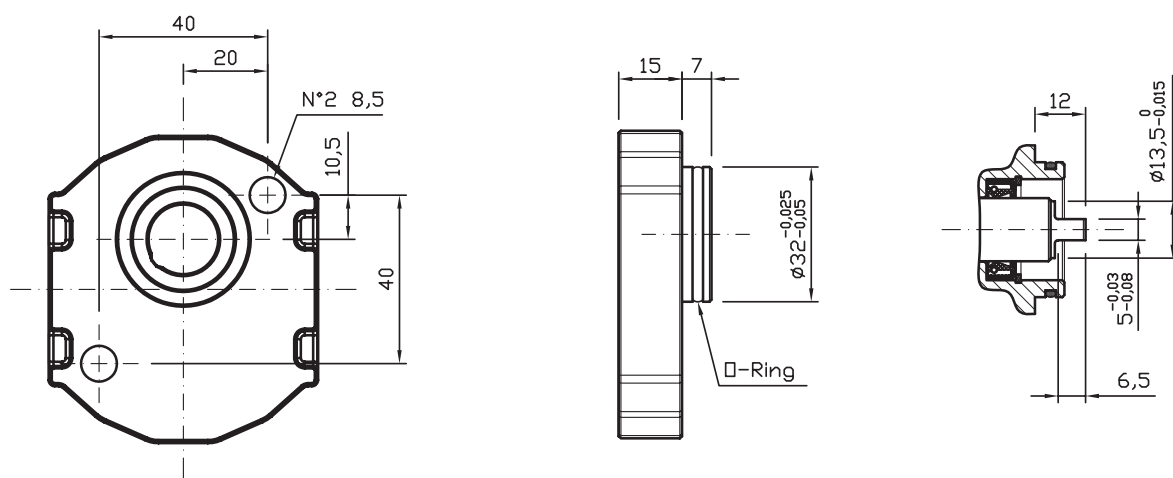

TYPE / TIPO 1K-GL54

Type Tipo	CC	L/min	Dimensions A Dimensioni A	Dimensions B Dimensioni B	Continuous Pressure Pressione continua	Intermittent Pressure Pressione intermittente (*)	Peak pressure Picco pressione (*)	Noise level Livello rumore
4	4,2	6,0	101,0	44,50	275	280	300	55
6	6,4	9,2	106,5	47,25	260	275	290	55
8	8,3	12,0	111,5	49,75	230	240	250	55
10	10,2	14,7	116,5	52,25	180	190	200	55
13	12,9	18,6	123,4	55,70	150	160	170	55

Max torque / Coppia max: 50 Nm

* Intermittent: cycle 20 sec. ON & 3 sec. OFF - Peak: cycle 1 sec. ON & 3 sec. OFF - Intermittente: ciclo 20 sec. ON & 3 sec. OFF - Picco: ciclo 1 sec. ON & 3 sec. OFF

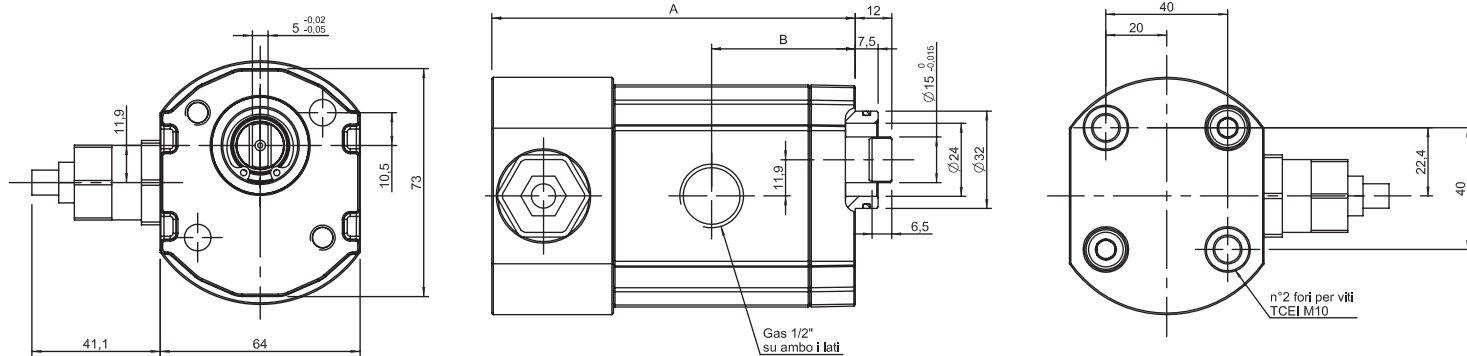

TYPE / TIPO 1K-GL54 (with safety valve / con valvola di massima)

Type Tipo	CC	L/min	Dimensions A Dimensioni A	Dimensions B Dimensioni B	Continuous Pressure Pressione continua	Intermittent Pressure Pressione intermittente (*)	Peak pressure Picco pressione (*)	Noise level Livello rumore
4	4,2	6,0	114,0	44,5	275	280	300	55
6	6,4	9,2	119,5	47,25	260	275	290	55
8	8,3	12,0	124,5	49,75	230	240	250	55
10	10,2	14,7	129,5	52,25	180	190	200	55
13	12,9	18,6	136,4	55,70	150	160	170	55

Max torque / Coppia max: 50 Nm

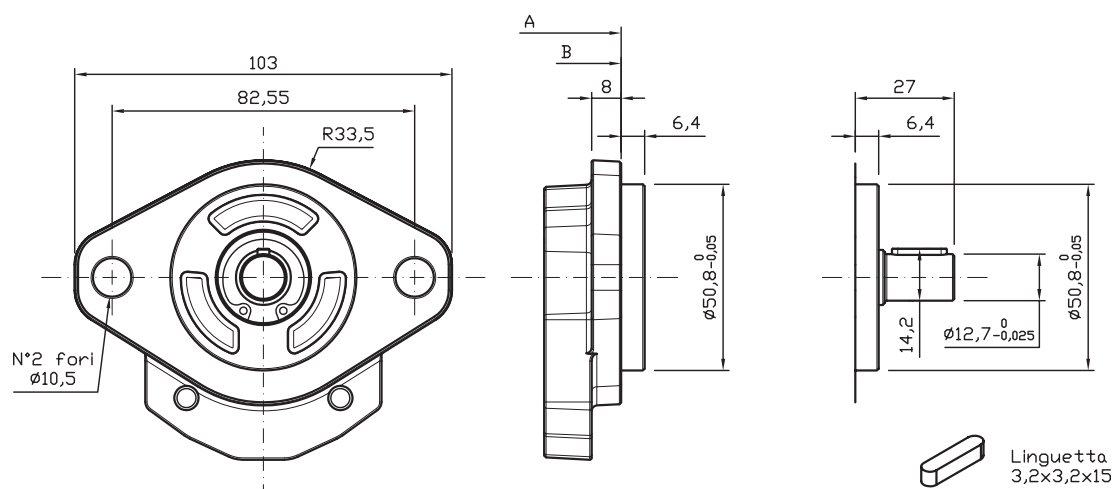

TYPE / TIPO SAEA-A - AC

Type Tipo	CC	L/min	Dimensions A Dimensioni A	Dimensions B Dimensioni B	Continuous Pressure Pressione continua	Intermittent Pressure Pressione intermittente (*)	Peak pressure Picco pressione (*)	Noise level Livello rumore
4	4,2	6,0	107,0	50,50	234	238	255	55
6	6,4	9,2	112,5	53,25	234	238	255	55
8	8,3	12,0	117,5	55,75	209	221	238	55
10	10,2	14,7	122,5	58,25	189	213	230	55
13	12,9	18,6	129,4	61,70	170	196	213	55

Max torque / Coppia max: 60 Nm

* Intermittent: cycle 20 sec. ON & 3 sec. OFF - Peak: cycle 1 sec. ON & 3 sec. OFF. Intermittente: ciclo 20 sec. ON & 3 sec. OFF - Picco: ciclo 1 sec. ON & 3 sec. OFF

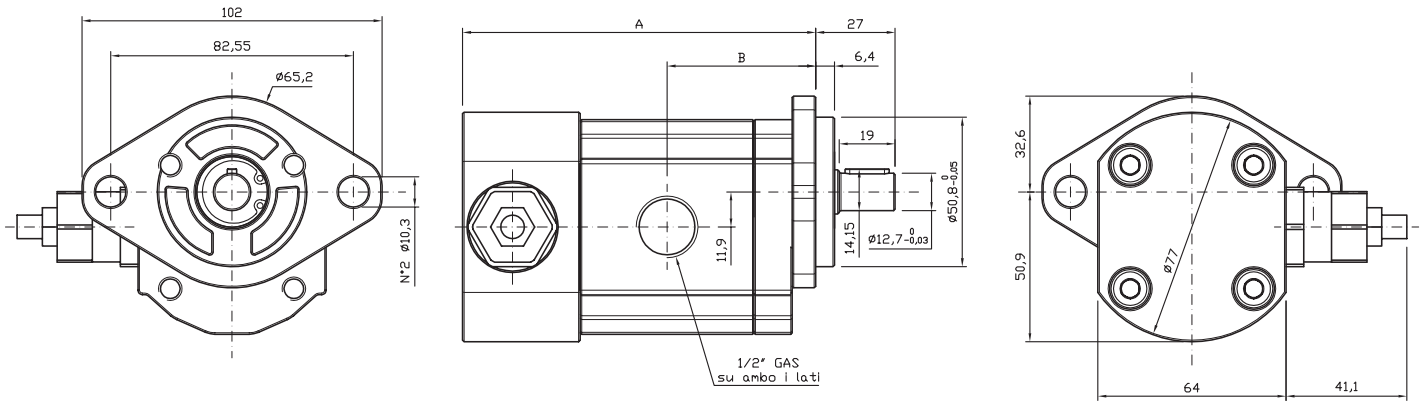

TYPE / TIPO SAEA-A - AC (with safety valve/con valvola di massima)

Type Tipo	CC	L/min	Dimensions A Dimensioni A	Dimensions B Dimensioni B	Continuous Pressure Pressione continua	Intermittent Pressure Pressione intermittente (*)	Peak pressure Picco pressione (*)	Noise level Livello rumore
4	4,2	6,0	120,0	50,50	234	238	255	55
6	6,4	9,2	125,5	53,25	234	238	255	55
8	8,3	12,0	130,5	55,75	209	221	238	55
10	10,2	14,7	135,5	58,25	189	213	230	55
13	12,9	18,6	142,4	61,70	170	196	213	55

Max torque / Coppia max: 60 Nm

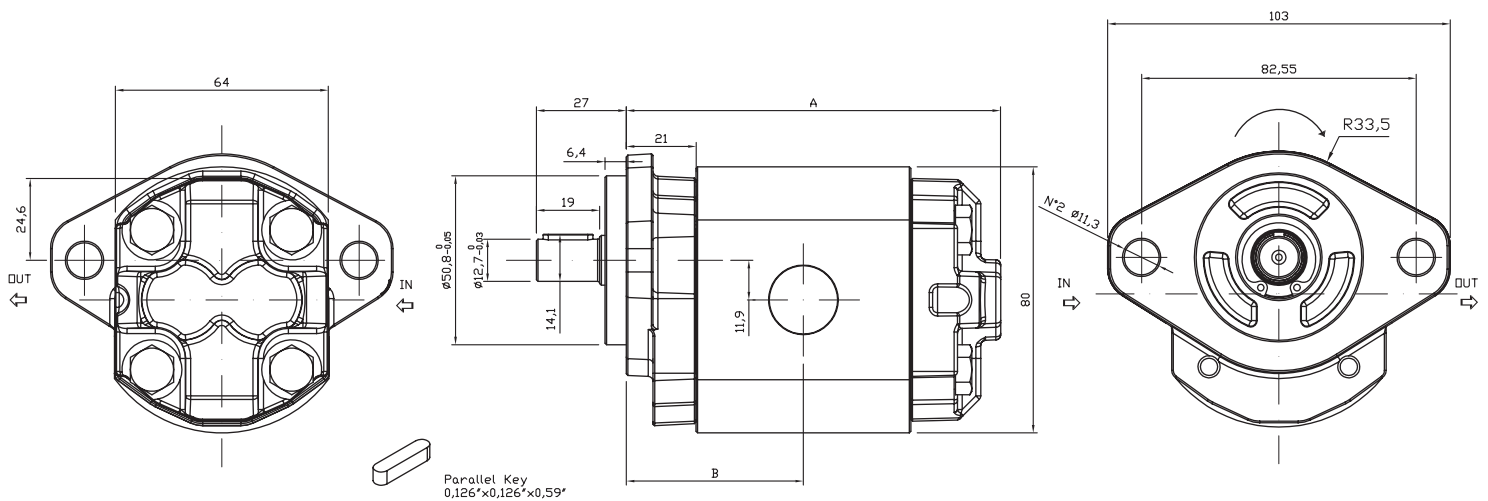

TYPE / TIPO SAE A-A SAE O-RING PORT UNF

Type Tipo	CC	L/min	Dimensions A Dimensioni A	Dimensions B Dimensioni B	Continuous Pressure Pressione continua	Intermittent Pressure Pressione intermittente (*)	Peak pressure Picco pressione (*)	Noise level Livello rumore
4	4,2	6,0	107,0	50,5	234	238	255	55
6	6,4	9,2	112,5	53,25	234	238	255	55
8	8,3	12,0	117,5	55,75	209	221	238	55
10	10,2	14,7	122,5	58,25	189	213	230	55
13	12,9	18,6	129,4	61,70	170	196	213	55

Max torque / Coppia max: 60 Nm

* Intermittent: cycle 20 sec. ON & 3 sec. OFF - Peak: cycle 1 sec. ON & 3 sec OFF. Intermittente: ciclo 20 sec. ON & 3 sec. OFF - Picco: ciclo 1 sec. ON & 3 sec OFF

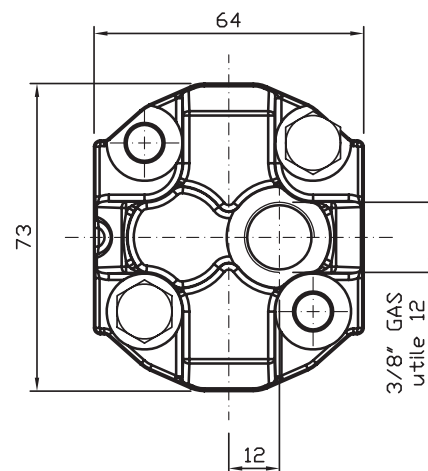
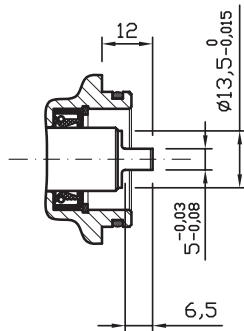
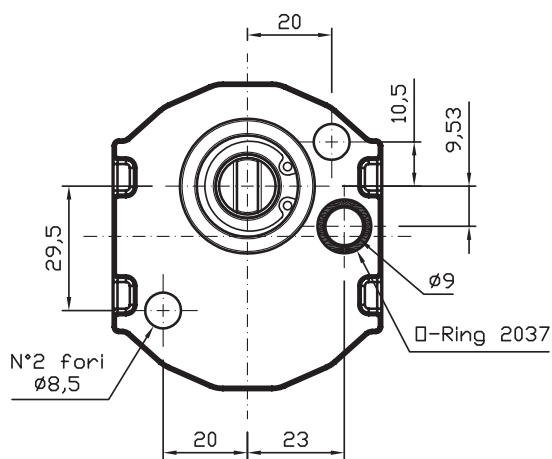

TYPE / TIPO 1L-GL54

Type Tipo	CC	L/min	Dimensions A Dimensioni A	Continuous Pressure Pressione continua	Intermittent Pressure Pressione intermittente (*)	Peak pressure Picco pressione (*)	Noise level Livello rumore
4	4,2	6,0	101,0	275	280	300	55
6	6,4	9,2	106,5	260	275	290	55
8	8,3	12,0	111,5	230	240	250	55
10	10,2	14,7	116,5	180	190	200	55
13	12,9	18,6	123,4	150	160	170	55

Max torque / Coppia max: 50 Nm

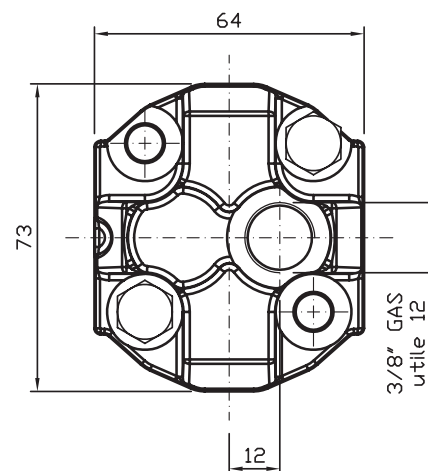
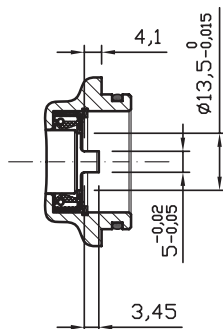
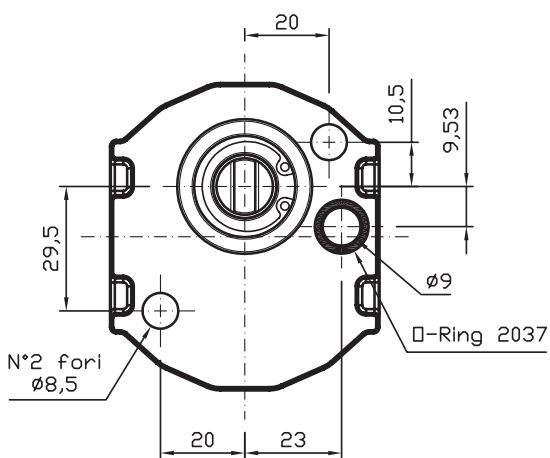

TYPE / TIPO 1L-G54

Type Tipo	CC	L/min	Dimensions A Dimensioni A	Continuous Pressure Pressione continua	Intermittent Pressure Pressione intermittente (*)	Peak pressure Picco pressione (*)	Noise level Livello rumore
4	4,2	6,0	101,0	275	280	300	55
6	6,4	9,2	106,5	230	240	270	55
8	8,3	12,0	111,5	180	200	210	55
10	10,2	14,7	116,5	150	160	170	55
13	12,9	18,6	123,4	120	130	140	55

Max torque / Coppia max: 40 Nm

* Intermittent: cycle 20 sec. ON & 3 sec. OFF - Peak: cycle 1 sec. ON & 3 sec OFF. Intermittente: ciclo 20 sec. ON & 3 sec. OFF - Picco: ciclo 1 sec. ON & 3 sec OFF

SHAFT AND FLANGE TYPE AND DIMENSIONS / TIPO ALBERO E FLANGE E DIMENSIONI

Group 2 pumps / Pompe gruppo 2

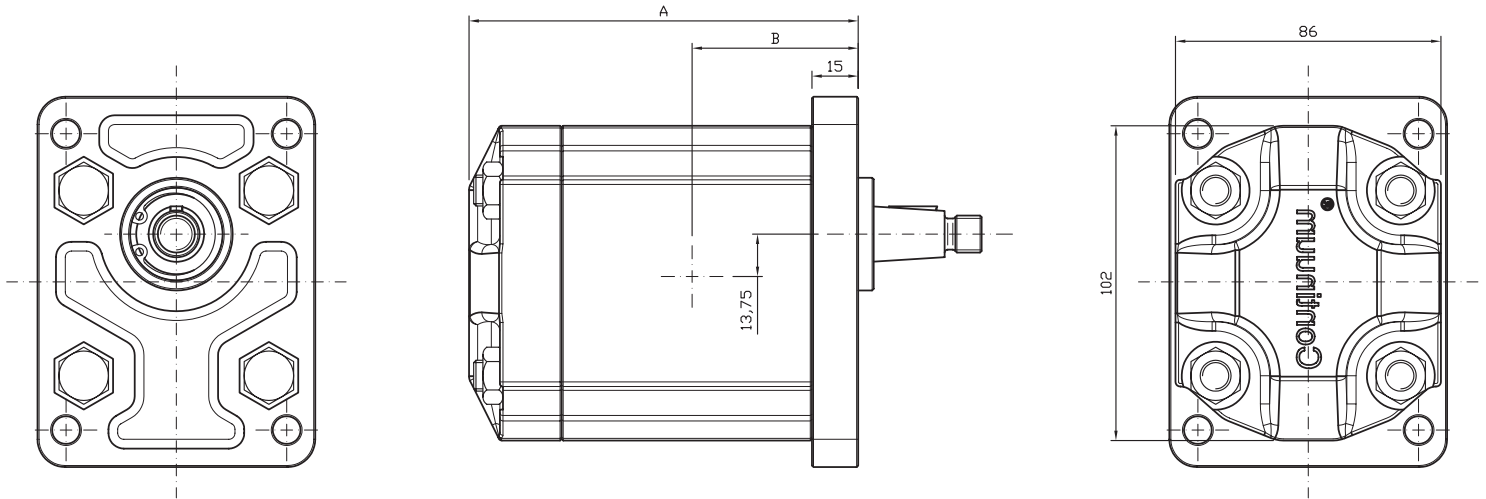

Available flanges and shafts / Flange ed alberi disponibili

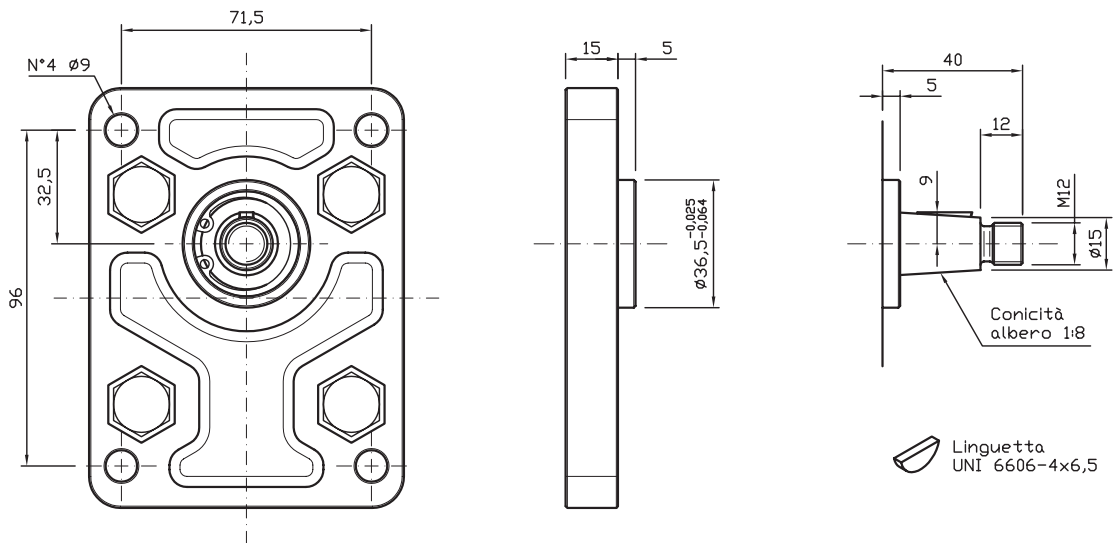

TYPE / TIPO 2-C4

Type Tipo	CC	L/min	Dimensions A Dimensioni A	Dimensions B Dimensioni B	Continuous Pressure Pressione continua	Intermittent Pressure Pressione intermittente (*)	Peak pressure Picco pressione (*)	Noise level Livello rumore
10	10,1	14,5	122,5	53,75	275	280	300	55
13	12,6	18,1	127,4	56,20	265	270	290	55
15	15,2	21,8	132,4	58,70	241	250	270	55
18	18,2	26,1	138,2	61,60	206	250	270	55

Max torque / Coppia max: 210 Nm

* Intermittent: cycle 20 sec. ON & 3 sec. OFF - Peak: cycle 1 sec. ON & 3 sec OFF. Intermittente: ciclo 20 sec. ON & 3 sec. OFF - Picco: ciclo 1 sec. ON & 3 sec OFF

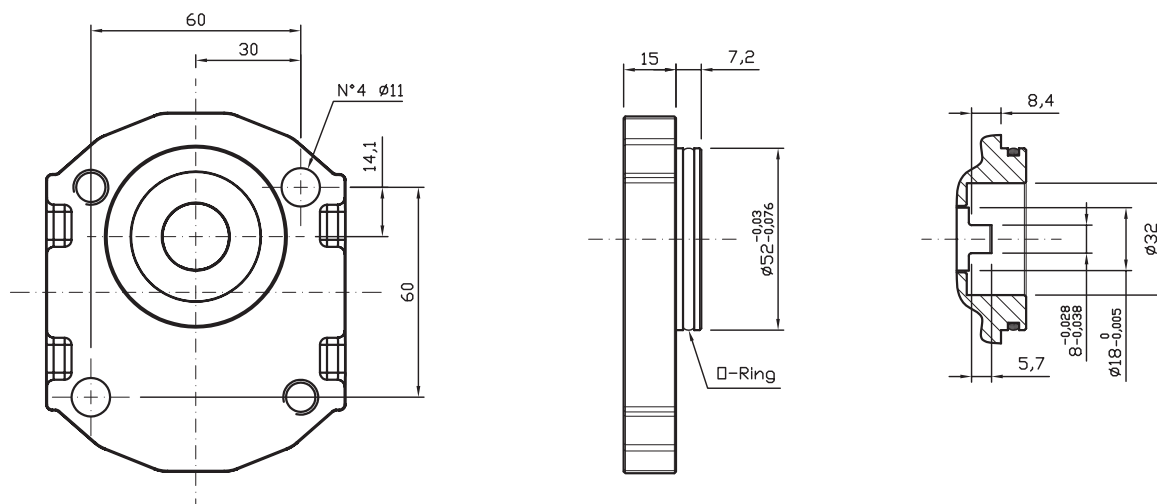

TYPE / TIPO 2BK7-AG

Type Tipo	CC	L/min	Dimensions A Dimensioni A	Dimensions B Dimensioni B	Continuous Pressure Pressione continua	Intermittent Pressure Pressione intermittente (*)	Peak pressure Picco pressione (*)	Noise level Livello rumore
10	10,1	14,5	122,5	53,75	275	280	300	55
13	12,6	18,1	127,4	56,20	265	270	290	55
15	15,2	21,8	132,4	58,70	241	250	270	55
18	18,2	26,1	138,2	61,60	206	250	270	55

Max torque / Coppia max: 110 Nm

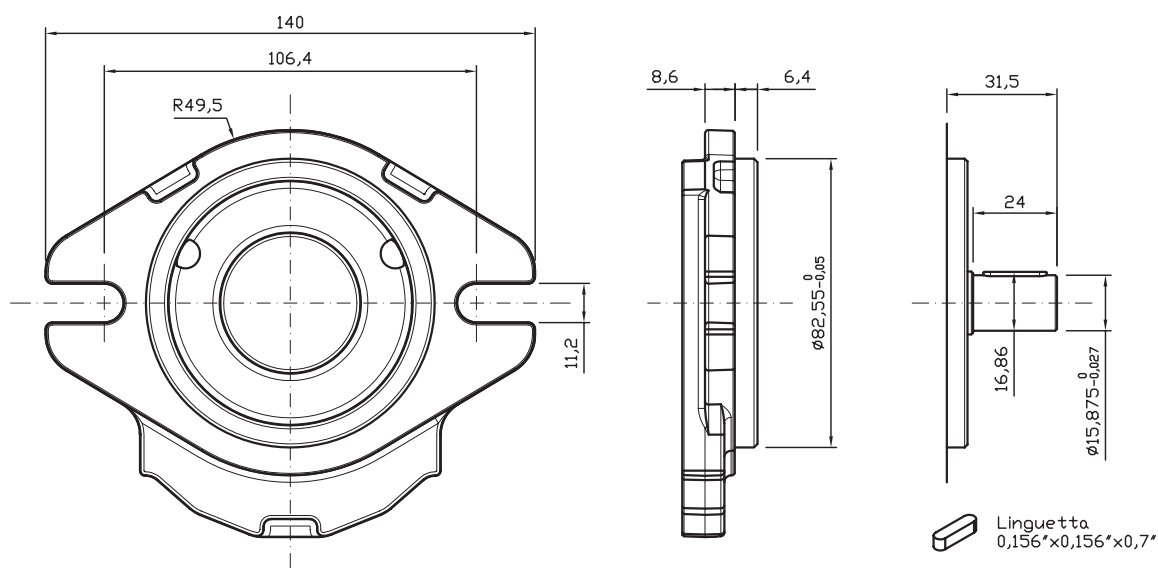

TYPE / TIPO SAEA-AC

Type Tipo	CC	L/min	Dimensions A Dimensioni A	Dimensions B Dimensioni B	Continuous Pressure Pressione continua	Intermittent Pressure Pressione intermittente (*)	Peak pressure Picco pressione (*)	Noise level Livello rumore
10	10,1	14,5	122,5	53,75	275	280	300	55
13	12,6	18,1	127,4	56,20	265	270	290	55
15	15,2	21,8	132,4	58,70	241	250	270	55
18	18,2	26,1	138,2	61,60	206	250	270	55

Max torque / Coppia max: 140 Nm

* Intermittent: cycle 20 sec. ON & 3 sec. OFF - Peak: cycle 1 sec. ON & 3 sec OFF. Intermittente: ciclo 20 sec. ON & 3 sec. OFF - Picco: ciclo 1 sec. ON & 3 sec OFF

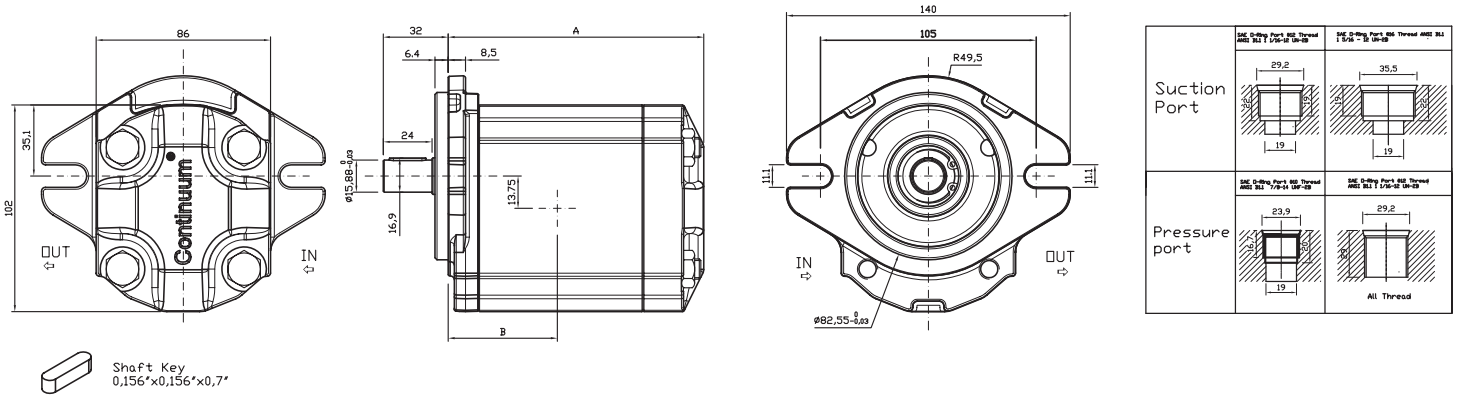

TYPE / TIPO SAE-AC SAE O-RING UNF								
Type Tipo	CC	L/min	Dimensions A Dimensioni A	Dimensions B Dimensioni B	Continuous Pressure Pressione continua	Intermittent Pressure Pressione intermittente (*)	Peak pressure Picco pressione (*)	Noise level Livello rumore
10	10,1	14,5	122,5	53,75	275	280	300	55
13	12,6	18,1	127,4	56,20	265	270	290	55
15	15,2	21,8	132,4	58,70	241	250	270	55
18	18,2	26,1	138,2	61,60	206	250	270	55

Max torque / Coppia max: 140 Nm

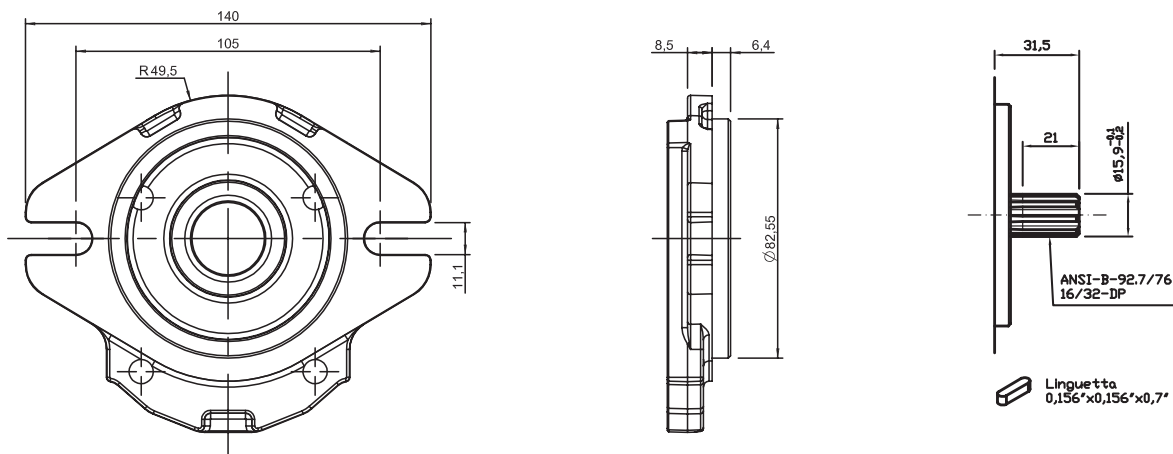

TYPE / TIPO SAE-T9								
Type Tipo	CC	L/min	Dimensions A Dimensioni A	Dimensions B Dimensioni B	Continuous Pressure Pressione continua	Intermittent Pressure Pressione intermittente (*)	Peak pressure Picco pressione (*)	Noise level Livello rumore
10	10,1	14,5	122,5	53,75	275	280	300	55
13	12,6	18,1	127,4	56,20	265	270	290	55
15	15,2	21,8	132,4	58,70	241	250	270	55
18	18,2	26,1	138,2	61,60	206	250	270	55

Max torque / Coppia max: 190 Nm

* Intermittent: cycle 20 sec. ON & 3 sec. OFF - Peak: cycle 1 sec. ON & 3 sec OFF. Intermittente: ciclo 20 sec. ON & 3 sec. OFF - Picco: ciclo 1 sec. ON & 3 sec OFF

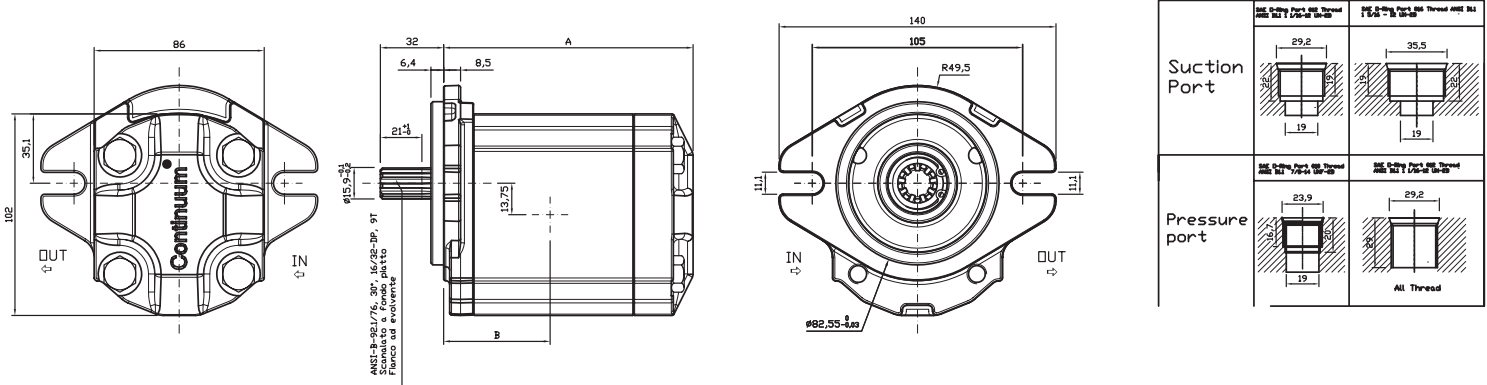

TYPE / TIPO SAE-T9 SAE O-RING UNF								
Type Tipo	CC	L/min	Dimensions A Dimensioni A	Dimensions B Dimensioni B	Continuous Pressure Pressione continua	Intermittent Pressure Pressione intermittente (*)	Peak pressure Picco pressione (*)	Noise level Livello rumore
10	10,1	14,5	122,5	53,75	275	280	300	55
13	12,6	18,1	127,4	56,20	265	270	290	55
15	15,2	21,8	132,4	58,70	241	250	270	55
18	18,2	26,1	138,2	61,60	206	250	270	55

Max torque / Coppia max: 190 Nm

* Intermittent: cycle 20 sec. ON & 3 sec. OFF - Peak: cycle 1 sec. ON & 3 sec OFF. Intermittente: ciclo 20 sec. ON & 3 sec. OFF - Picco: ciclo 1 sec. ON & 3 sec OFF

INLET OUTLET PORTS / PORTE DI ASPIRAZIONE E MANDATA

Type G / Tipo G

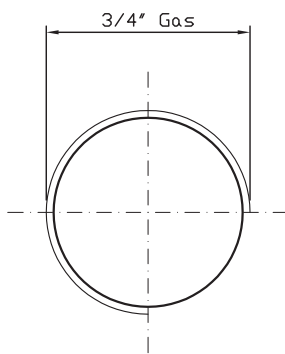

Inlet/Outlet

Type M / Tipo M

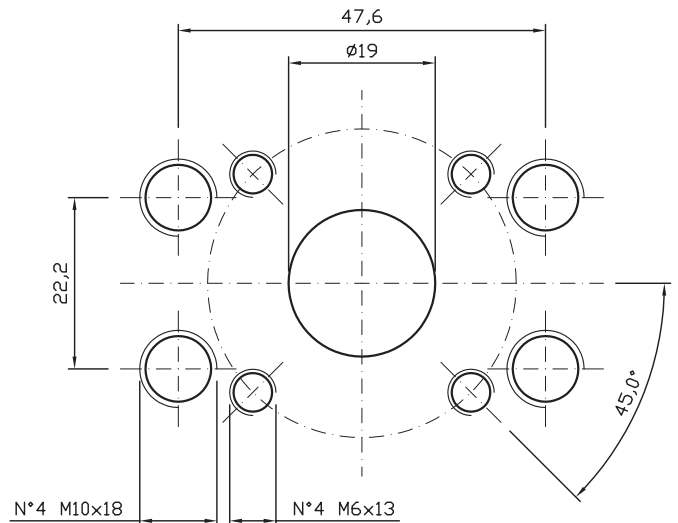

Inlet/Outlet

SHAFT AND FLANGE TYPE AND DIMENSIONS / TIPO ALBERO E FLANGE E DIMENSIONI

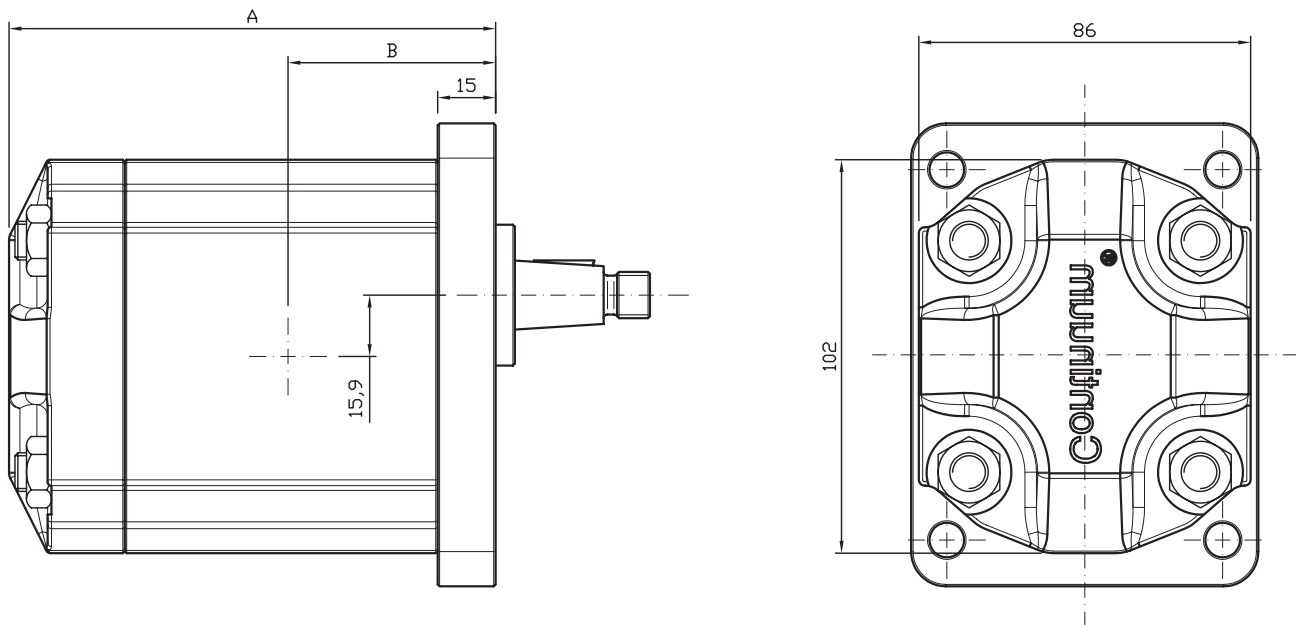

Available flanges and shafts / Flange ed alberi disponibili

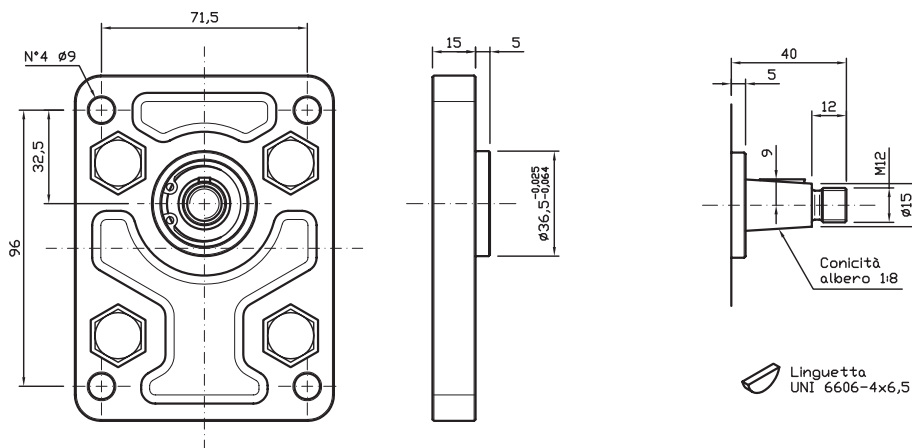

TYPE / TIPO 2-C4

Type Tipo	CC	L/min	Dimensions A Dimensioni A	Dimensions B Dimensioni B	Continuous Pressure Pressione continua	Intermittent Pressure Pressione intermittente (*)	Peak pressure Picco pressione (*)	Noise level Livello rumore
16	15,9	22,8	126,0	55,50	265	280	300	55
18	17,9	25,8	129,0	57,00	247	260	280	55
20	20,0	28,8	132,0	58,50	230	250	270	55
22	22,1	31,8	135,0	60,00	222	240	260	55
25	25,2	36,2	139,5	62,25	200	210	220	55
28	28,3	40,7	144,0	64,50	180	190	200	55

Max torque / Coppia max: 210 Nm

* Intermittent: cycle 20 sec. ON & 3 sec. OFF - Peak: cycle 1 sec. ON & 3 sec. OFF. Intermittente: ciclo 20 sec. ON & 3 sec. OFF - Picco: ciclo 1 sec. ON & 3 sec. OFF

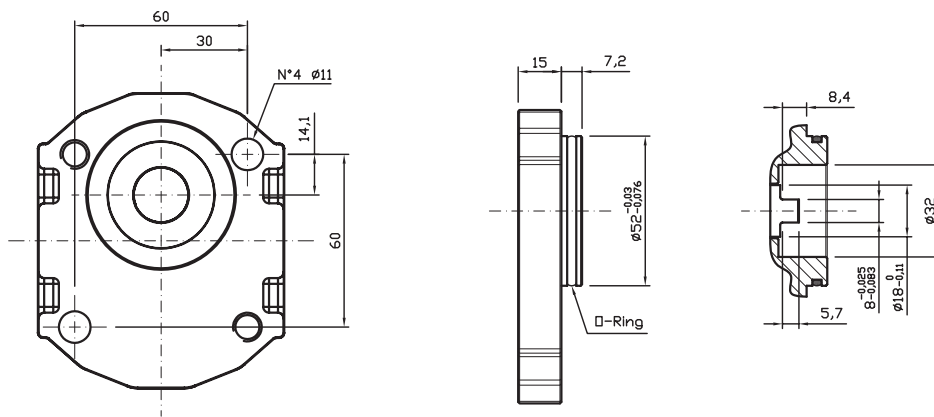

TYPE / TIPO 2BK7-AG

Type Tipo	CC	L/min	Dimensions A Dimensioni A	Dimensions B Dimensioni B	Continuous Pressure Pressione continua	Intermittent Pressure Pressione intermittente (*)	Peak pressure Picco pressione (*)	Noise level Livello rumore
16	15,9	22,8	126,0	55,50	265	280	300	55
18	17,9	25,8	129,0	57,00	247	260	280	55
20	20,0	28,8	132,0	58,50	230	250	260	55
22	22,1	31,8	135,0	60,00	210	230	240	55
25	25,2	36,2	139,5	62,25	200	210	220	55
28	28,3	40,7	144,0	64,50	180	190	200	55

Max torque / Coppia max: 110 Nm

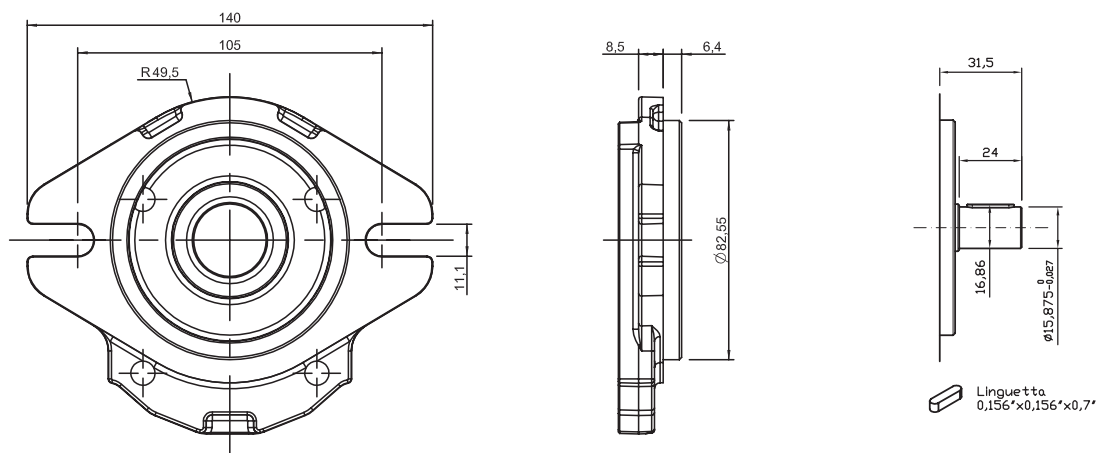

TYPE / TIPO SAEA-AC

Type Tipo	CC	L/min	Dimensions A Dimensioni A	Dimensions B Dimensioni B	Continuous Pressure Pressione continua	Intermittent Pressure Pressione intermittente (*)	Peak pressure Picco pressione (*)	Noise level Livello rumore
16	15,9	22,8	126,0	55,50	265	280	300	55
18	17,9	25,8	129,0	57,00	247	260	280	55
20	20,0	28,8	132,0	58,50	230	250	270	55
22	22,1	31,8	135,0	60,00	222	240	260	55
25	25,2	36,2	139,5	62,25	200	210	220	55
28	28,3	40,7	144,0	64,50	180	190	200	55

Max torque / Coppia max: 140 Nm

* Intermittent: cycle 20 sec. ON & 3 sec. OFF - Peak: cycle 1 sec. ON & 3 sec OFF. Intermittente: ciclo 20 sec. ON & 3 sec. OFF - Picco: ciclo 1 sec. ON & 3 sec OFF

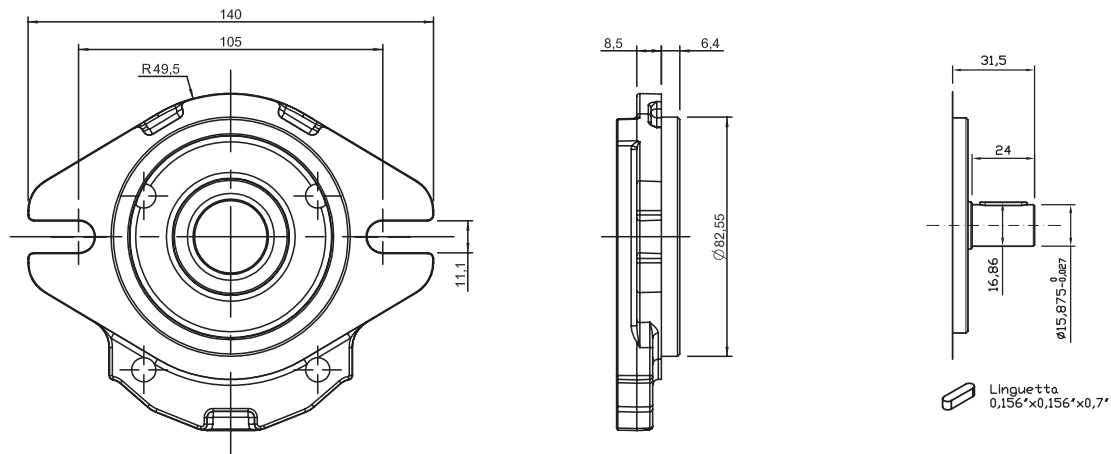

TYPE / TIPO SAEA-AC SAE O-RING PORT UNF

Type Tipo	CC	L/min	Dimensions A Dimensioni A	Dimensions B Dimensioni B	Continuous Pressure Pressione continua	Intermittent Pressure Pressione intermittente (*)	Peak pressure Picco pressione (*)	Noise level Livello rumore
16	15,9	22,8	126,0	55,50	265	280	300	55
18	17,9	25,8	129,0	57,00	247	260	280	55
20	20,0	28,8	132,0	58,50	230	250	270	55
22	22,1	31,8	135,0	60,00	222	240	260	55
25	25,2	36,2	139,5	62,25	200	210	220	55
28	28,3	40,7	144,0	64,50	180	190	200	55

Max torque / Coppia max: 140 Nm

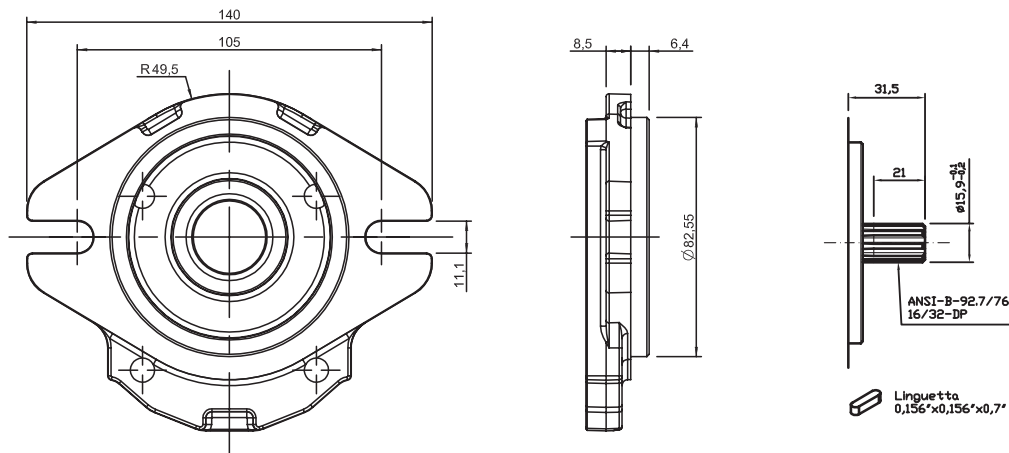

TYPE / TIPO SAEA-T9

Type Tipo	CC	L/min	Dimensions A Dimensioni A	Dimensions B Dimensioni B	Continuous Pressure Pressione continua	Intermittent Pressure Pressione intermittente (*)	Peak pressure Picco pressione (*)	Noise level Livello rumore
16	15,9	22,8	126,0	55,50	265	280	300	55
18	17,9	25,8	129,0	57,00	247	260	280	55
20	20,0	28,8	132,0	58,50	230	250	270	55
22	22,1	31,8	135,0	60,00	222	240	260	55
25	25,2	36,2	139,5	62,25	200	210	220	55
28	28,3	40,7	144,0	64,50	180	190	200	55

Max torque / Coppia max: 190 Nm

* Intermittent: cycle 20 sec. ON & 3 sec. OFF - Peak: cycle 1 sec. ON & 3 sec OFF. Intermittente: ciclo 20 sec. ON & 3 sec. OFF - Picco: ciclo 1 sec. ON & 3 sec OFF

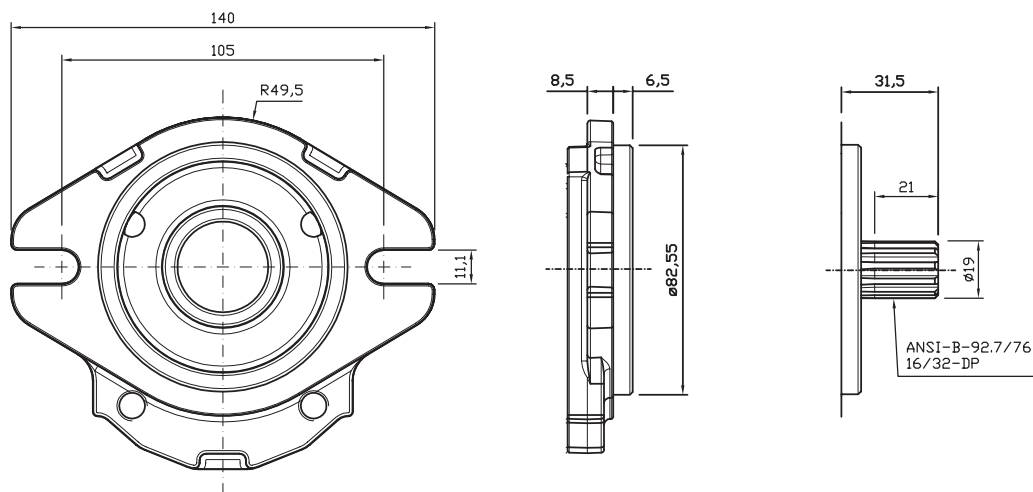

TYPE / TIPO SAE-T11

Type Tipo	CC	L/min	Dimensions A Dimensioni A	Dimensions B Dimensioni B	Continuous Pressure Pressione continua	Intermittent Pressure Pressione intermittente (*)	Peak pressure Picco pressione (*)	Noise level Livello rumore
16	15,9	22,8	126,0	55,50	265	280	300	55
18	17,9	25,8	129,0	57,00	247	260	280	55
20	20,0	28,8	132,0	58,50	230	250	270	55
22	22,1	31,8	135,0	60,00	222	250	270	55
25	25,2	36,2	139,5	62,25	208	250	270	55
28	28,3	40,7	144,0	64,50	197	250	270	55

Max torque / Coppia max: 210 Nm

* Intermittent: cycle 20 sec. ON & 3 sec. OFF - Peak: cycle 1 sec. ON & 3 sec OFF. Intermittente: ciclo 20 sec. ON & 3 sec. OFF - Picco: ciclo 1 sec. ON & 3 sec OFF

INLET OUTLET PORTS / PORTE DI ASPIRAZIONE E MANDATA

Type G / Tipo G

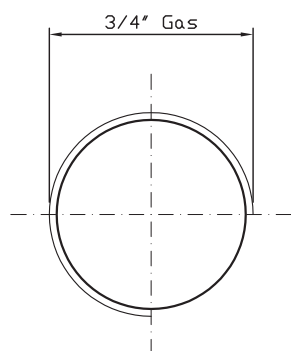

Inlet/Outlet

Type M / Tipo M

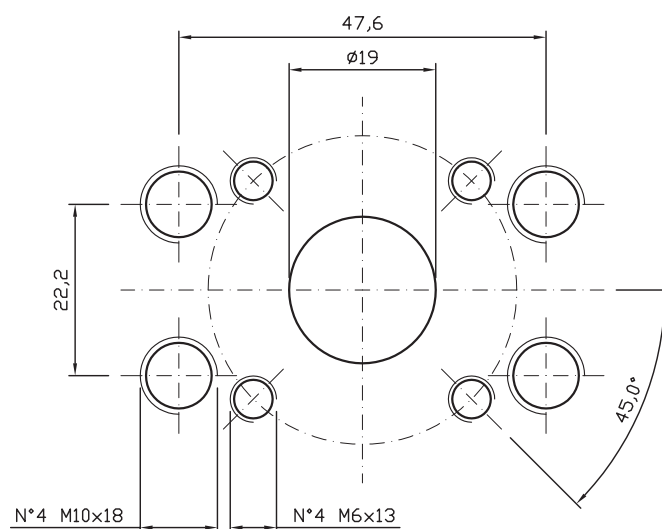

Inlet/Outlet

SHAFT AND FLANGE TYPE AND DIMENSIONS / TIPO ALBERO E FLANGE E DIMENSIONI

Group 3 pumps / Pompe gruppo 3

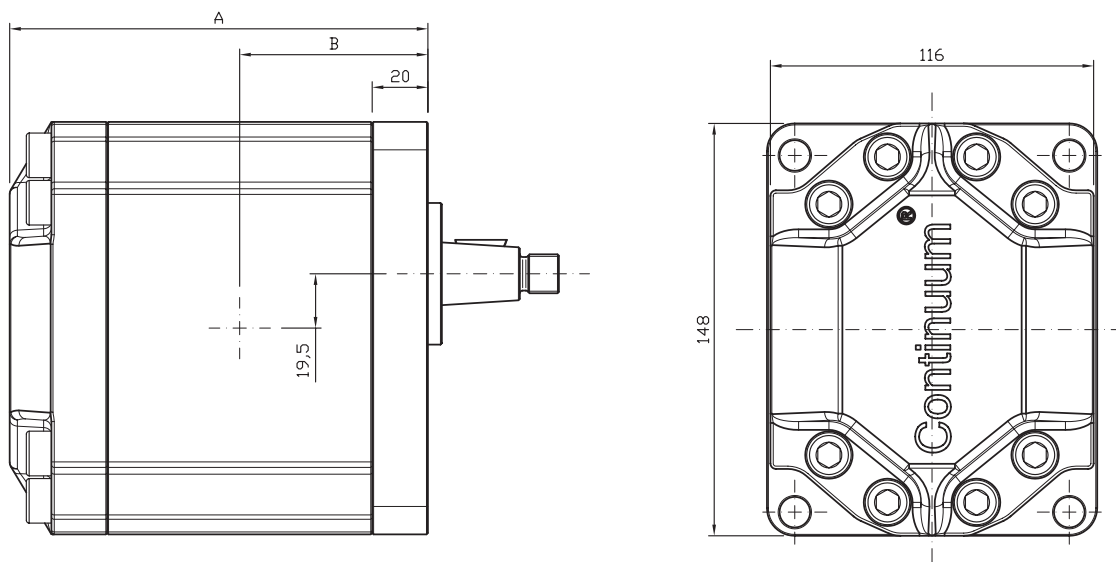

Available flanges and shafts / Flange ed alberi disponibili

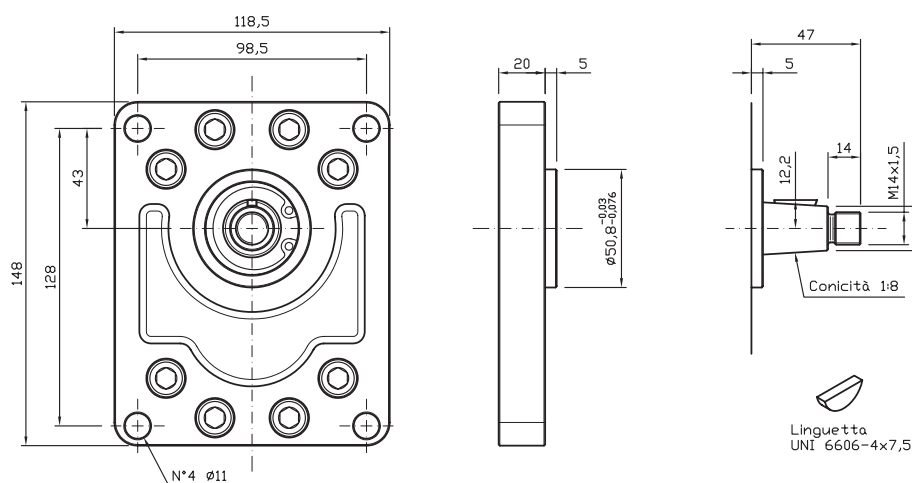

TYPE / TIPO 3-C9

Type Tipo	CC	L/min	Dimensions A Dimensioni A	Dimensions B Dimensioni B	Continuous Pressure Pressione continua	Intermittent Pressure Pressione intermittente (*)	Peak pressure Picco pressione (*)	Noise level Livello rumore
28	28,0	40,3	151,5	67,50	270	280	300	57
32	32,2	46,3	155,5	69,50	252	270	280	57
36	36,3	52,3	159,5	71,50	239	250	270	57
40	40,5	58,3	163,5	73,50	225	250	270	57
45	45,5	65,0	168,0	75,75	213	250	270	57
50	50,3	72,4	173,0	78,25	202	250	270	57

Max torque / Coppia max: 320 Nm

* Intermittent: cycle 20 sec. ON & 3 sec. OFF - Peak: cycle 1 sec. ON & 3 sec. OFF. Intermittente: ciclo 20 sec. ON & 3 sec. OFF - Picco: ciclo 1 sec. ON & 3 sec. OFF

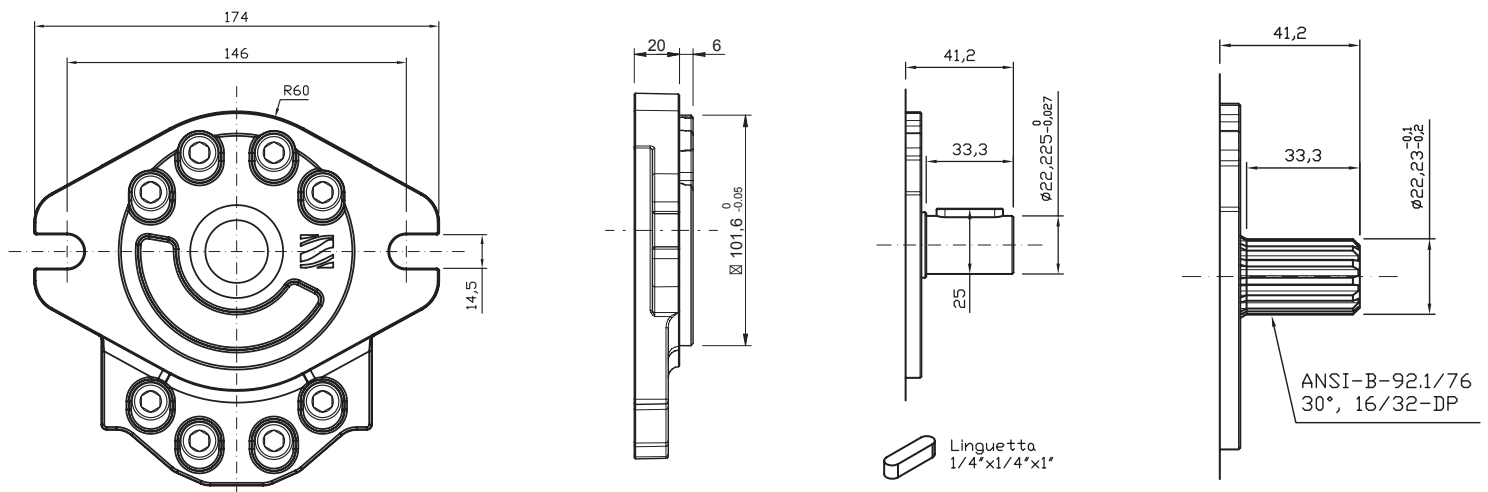

TYPE / TIPO SAEB-AC / SAEB-T13

Type Tipo	CC	L/min	Dimensions A Dimensioni A	Dimensions B Dimensioni B	Continuous Pressure Pressione continua	Intermittent Pressure Pressione intermittente (*)	Peak pressure Picco pressione (*)	Noise level Livello rumore
28	28,0	40,3	151,5	67,50	270	280	300	57
32	32,2	46,3	155,5	69,50	252	270	280	57
36	36,3	52,3	159,5	71,50	239	250	270	57
40	40,5	58,3	163,5	73,50	225	250	270	57
45	45,5	65,0	168,0	75,75	213	250	270	57
50	50,3	72,4	173,0	78,25	202	250	270	57

Max torque / Coppia max: 450 Nm - Max torque / Coppia max: 600 Nm

INLET OUTLET PORTS / PORTE DI ASPIRAZIONE E MANDATA

Inlet SAE 3000 from 1" ¼

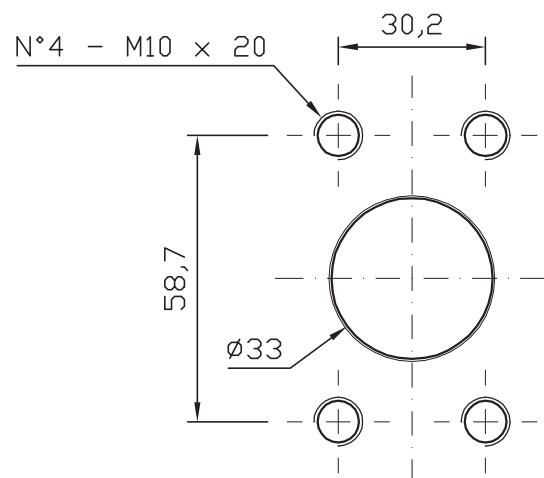

Outlet SAE 3000 from ¾"

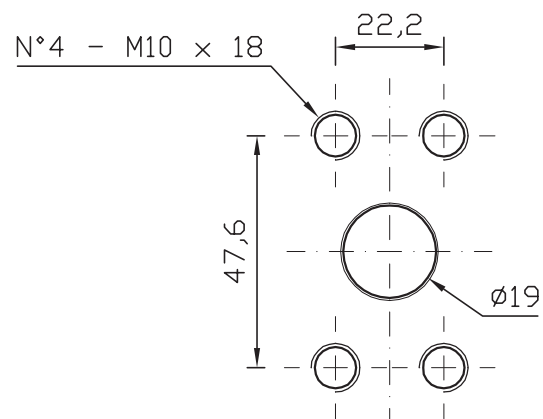

* Intermittent: cycle 20 sec. ON & 3 sec. OFF - Peak: cycle 1 sec. ON & 3 sec OFF. Intermittente: ciclo 20 sec. ON & 3 sec. OFF - Picco: ciclo 1 sec. ON & 3 sec OFF

SHAFT AND FLANGE TYPE AND DIMENSIONS / TIPO ALBERO E FLANGE E DIMENSIONI

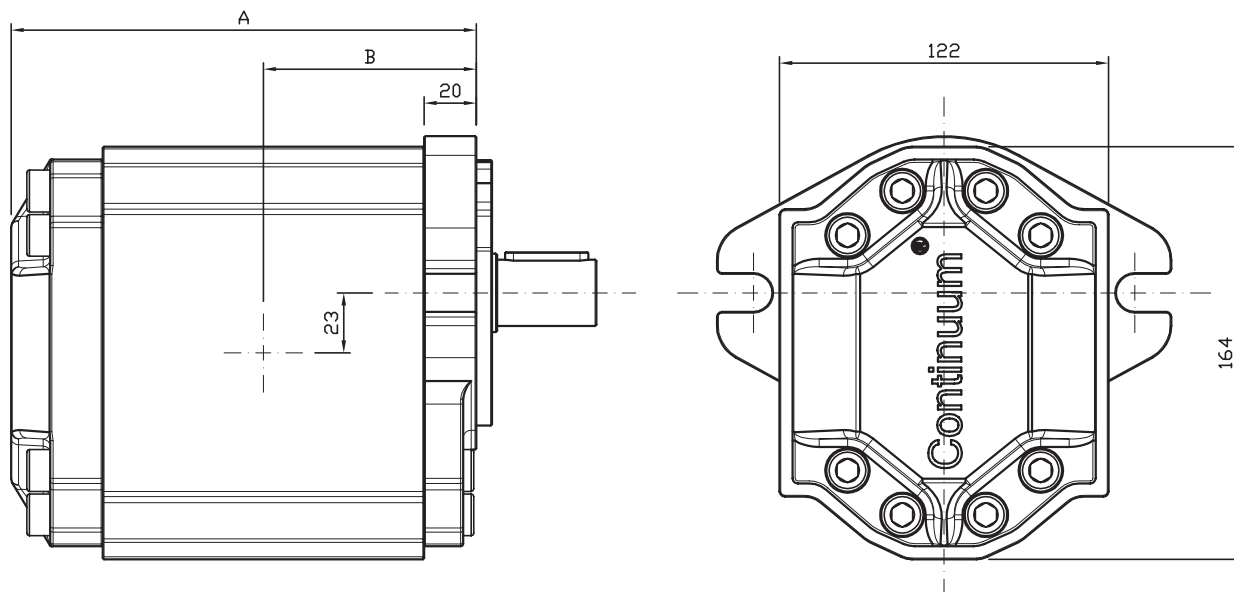

Available flanges and shafts / Flange ed alberi disponibili

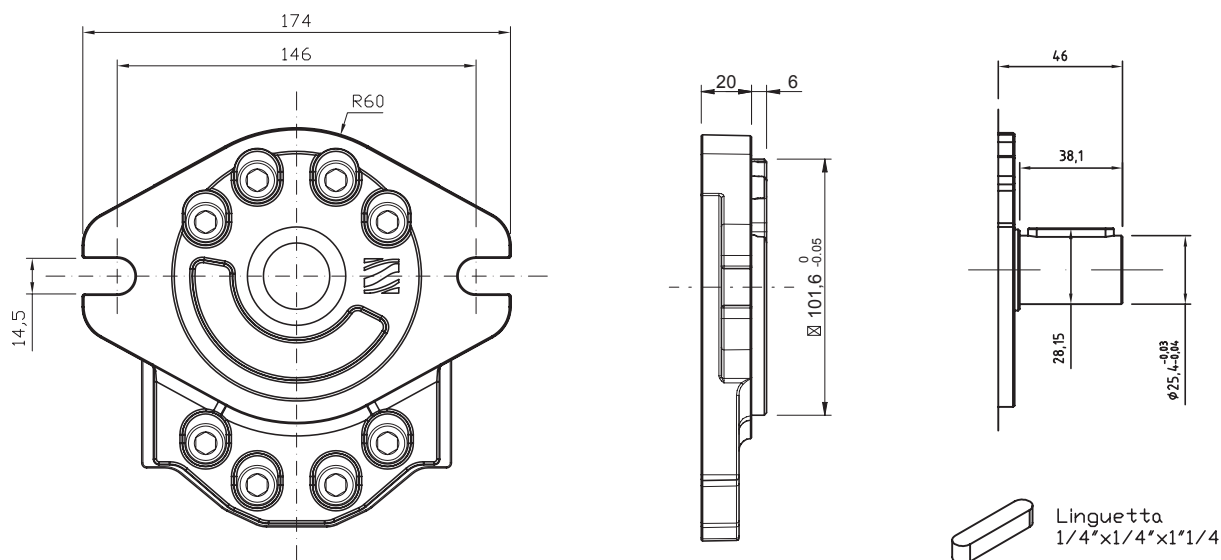

TYPE / TIPO SAEB-AC

Type Tipo	CC	L/min	Dimensions A Dimensioni A	Dimensions B Dimensioni B	Continuous Pressure Pressione continua	Intermittent Pressure Pressione intermittente (*)	Peak pressure Picco pressione (*)	Noise level Livello rumore
50	50,5	72,7	179,5	81,50	275	280	300	57
63	63,5	91,4	188,5	86,00	249	260	280	57
75	75,0	108,1	196,5	90,00	229	250	270	57
90	90,9	130,9	207,5	95,5	178	240	260	57

Max torque / Coppia max: 550 Nm

* Intermittent: cycle 20 sec. ON & 3 sec. OFF - Peak: cycle 1 sec. ON & 3 sec OFF. Intermittente: ciclo 20 sec. ON & 3 sec. OFF - Picco: ciclo 1 sec. ON & 3 sec OFF

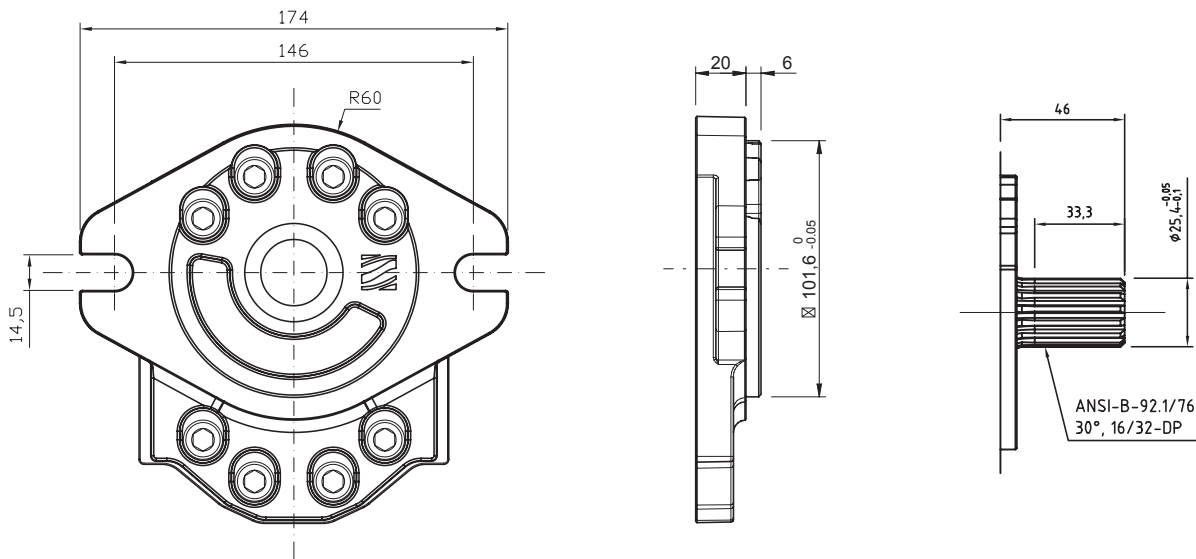

TYPE / TIPO SAEB-T15

Type Tipo	CC	L/min	Dimensions A Dimensioni A	Dimensions B Dimensioni B (**)	Continuous Pressure Pressione continua	Intermittent Pressure Pressione intermittente (*)	Peak pressure Picco pressione (*)	Noise level Livello rumore
50	50,5	72,7	179,5	81,50	275	280	300	57
63	63,5	91,4	188,5	86,00	249	260	280	57
75	75,0	108,1	196,5	90,00	229	250	270	57
90	90,9	130,9	207,5	95,50	178	240	260	57

Max torque / Coppia max: 700 Nm

* Intermittent: cycle 20 sec. ON & 3 sec. OFF - Peak: cycle 1 sec. ON & 3 sec OFF. Intermittente: ciclo 20 sec. ON & 3 sec. OFF - Picco: ciclo 1 sec. ON & 3 sec OFF

** Ask SETTIMA the dimensional drawings for "OE" suction port

INLET OUTLET PORTS / PORTE DI ASPIRAZIONE E MANDATA

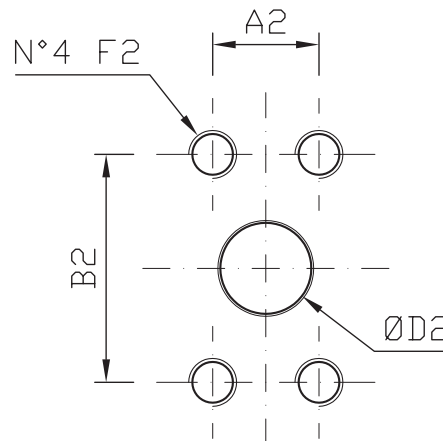
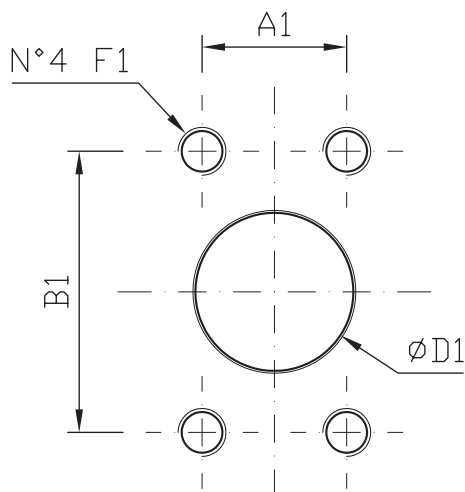

INLET			
Type port	"O"	"OE"	
Size port	SAE-3000 1" ¼	SAE-3000 1" ¼ only for 50cc	SAE-3000 1" ½
A1	30,20	30,20	35,70
B1	58,70	58,70	69,85
ØD1	33,00	33,00	38,00
F1	M10x20	M10x18	M10x18

OUTLET		
Type port	"O"	"OE"
Size port	SAE-3000 ¾"	SAE-3000 1"
A2	22,20	26,20
B2	47,60	52,40
ØD2	19,00	25,00
F2	M10X18	M10X18

SHAFT AND FLANGE TYPE AND DIMENSIONS / TIPO ALBERO E FLANGE E DIMENSIONI

Group 4 pumps / Pompe gruppo 4

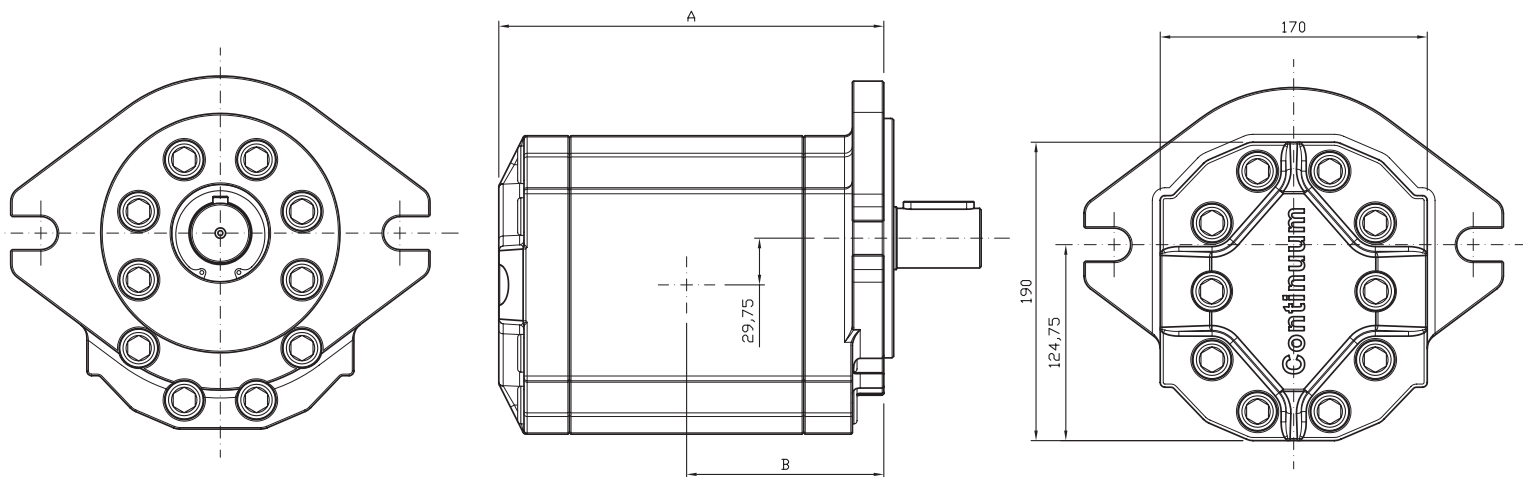

Available flanges and shafts / Flange ed alberi disponibili

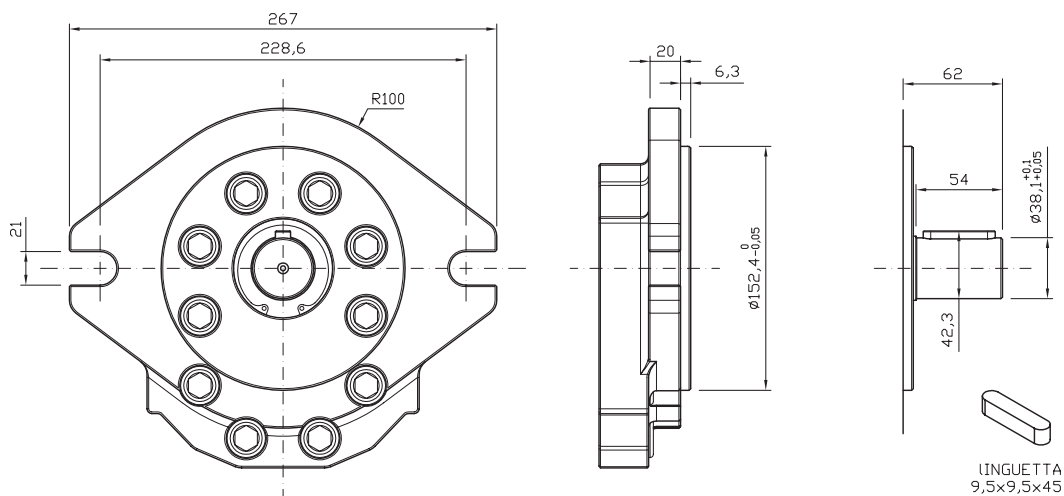

TYPE / TIPO SAED-AC

Type Tipo	CC	L/min	Dimensions A Dimensioni A	Dimensions B Dimensioni B	Continuous Pressure Pressione continua	Intermittent Pressure Pressione intermittente (*)	Peak pressure Picco pressione (*)	Noise level Livello rumore
94	94,1	136	245,0	125,65	240	250	260	57
101	101,4	147	248,0	127,05	230	240	250	57
125	125,5	181	258,0	132,15	220	220	230	57
150	150,9	218	268,5	137,40	200	210	220	57
175	175,0	253	278,5	142,40	180	190	200	57
200	200,4	290	289,0	147,65	160	170	180	57

Max torque / Coppia max: 1000 Nm

* Intermittent: cycle 20 sec. ON & 3 sec. OFF - Peak: cycle 1 sec. ON & 3 sec. OFF. Intermittente: ciclo 20 sec. ON & 3 sec. OFF - Picco: ciclo 1 sec. ON & 3 sec. OFF

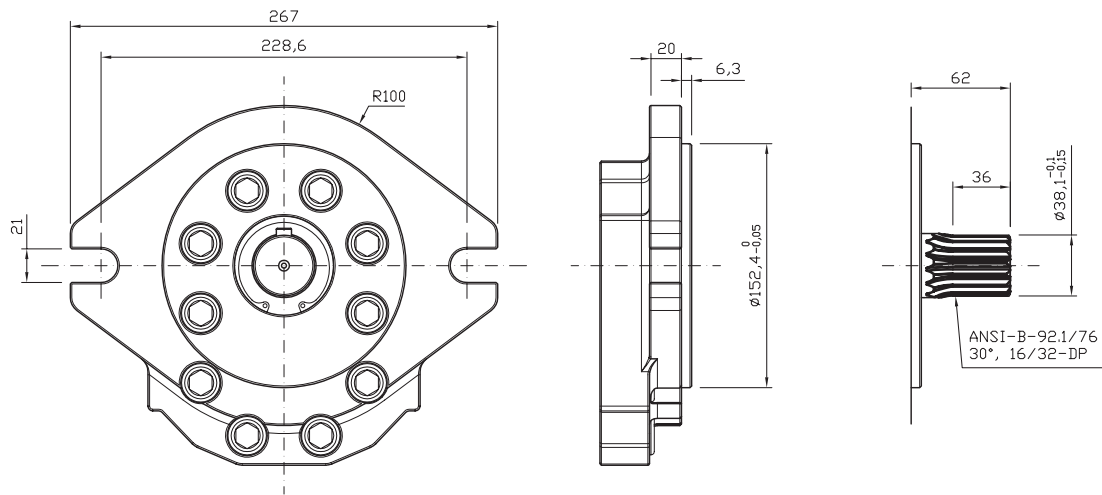

TYPE / TIPO SAED-T23

Type Tipo	CC	L/min	Dimensions A Dimensioni A	Dimensions B Dimensioni B	Continuous Pressure Pressione continua	Intermittent Pressure Pressione intermittente (*)	Peak pressure Picco pressione (*)	Noise level Livello rumore
94	94,1	136	245,0	125,50	240	250	260	57
101	101,4	147	248,0	127,00	230	240	250	57
125	125,5	181	258,0	132,00	220	220	230	57
150	150,9	218	268,5	137,25	200	210	220	57
175	175,0	253	278,5	142,25	180	190	200	57
200	200,4	290	289,0	147,50	160	170	180	57

Max torque / Coppia max: 1200 Nm

* Intermittent: cycle 20 sec. ON & 3 sec. OFF - Peak: cycle 1 sec. ON & 3 sec OFF. Intermittente: ciclo 20 sec. ON & 3 sec. OFF - Picco: ciclo 1 sec. ON & 3 sec OFF

INLET OUTLET PORTS / PORTE DI ASPIRAZIONE E MANDATA

Type / Tipo ME SAE 3000 2" 1/2

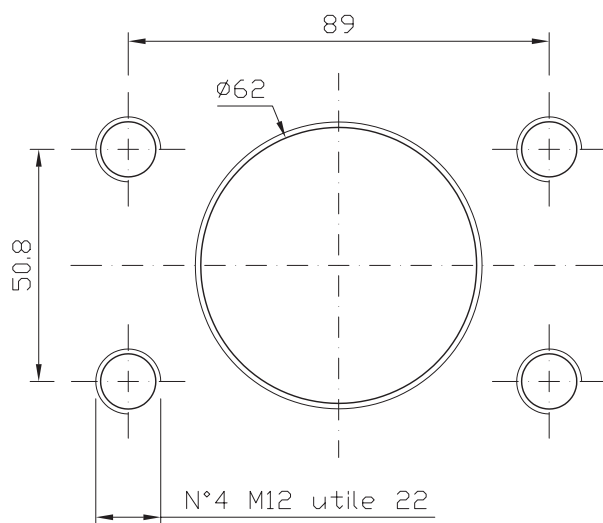

Inlet

Type / Tipo ME SAE 6000 1" 1/2

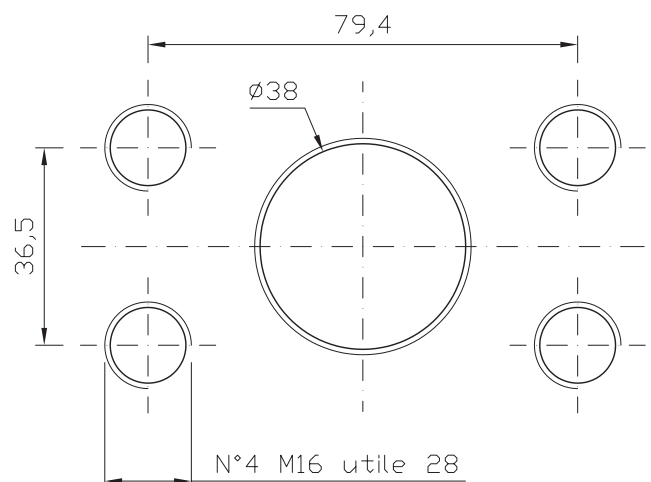

Outlet

Flow performances @ 46 cSt

GR 28 1-C3
GR 28 1L-GL54
GR 28 1L-G54

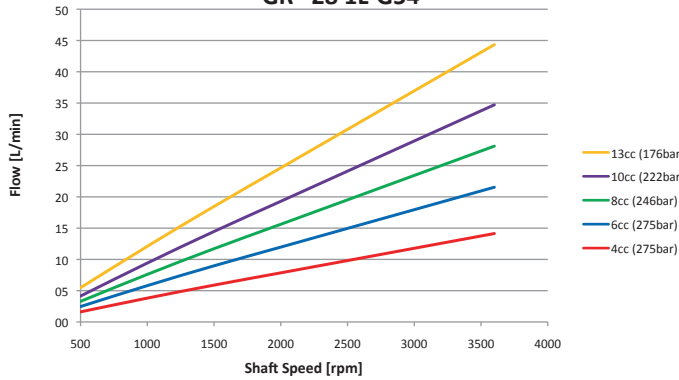

GR 28 1P-C2

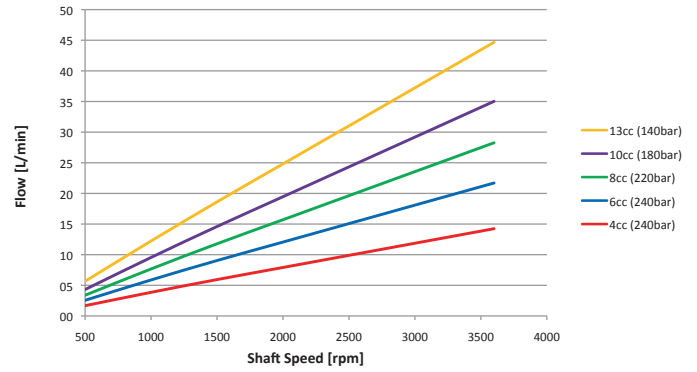

GR 28 1K-G54
GR 28 1K-GL54

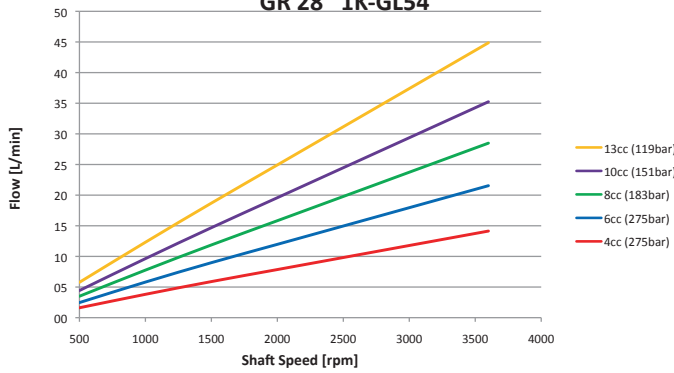

GR 28 SAEA-AC

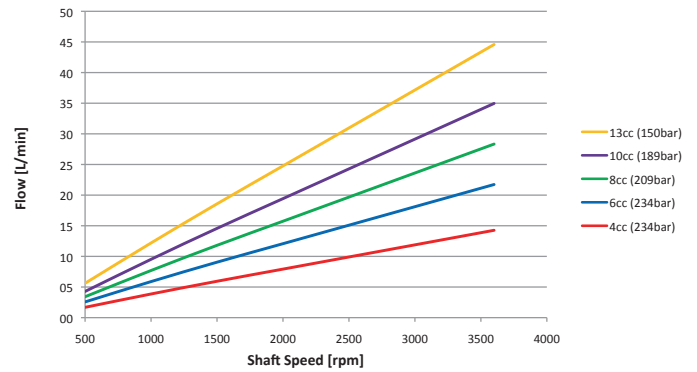

GR 33

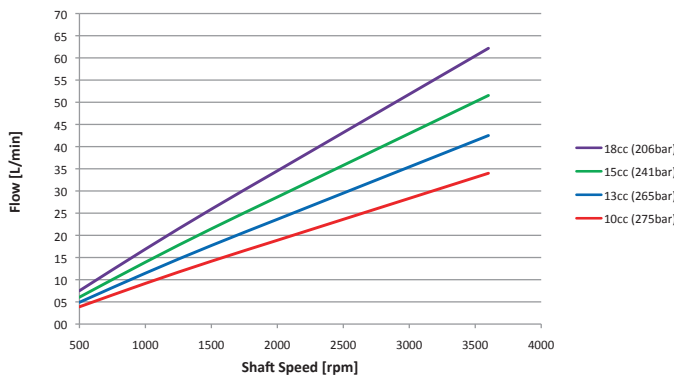

GR 38

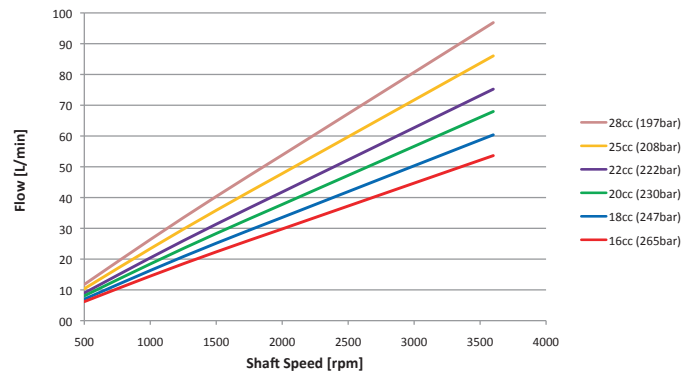

GR 47

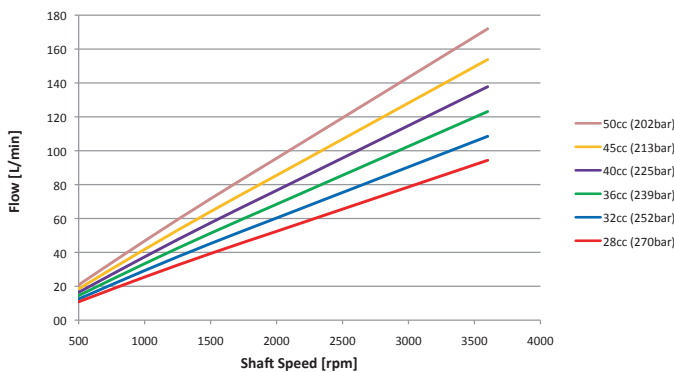

GR 55

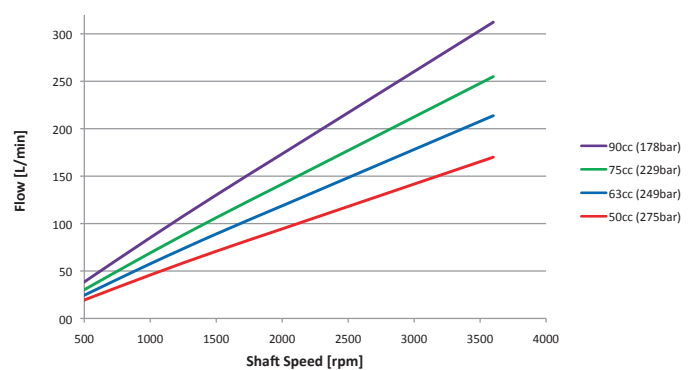

GR 72

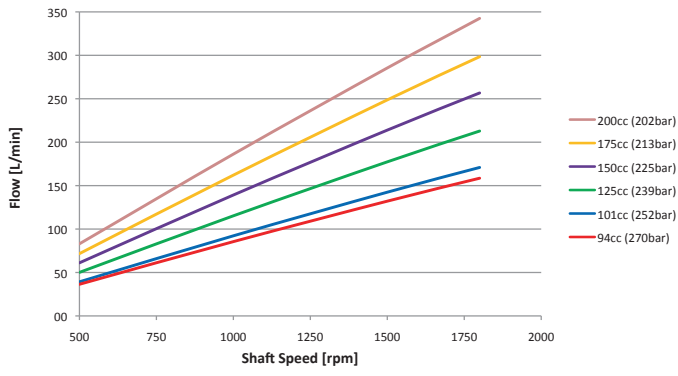

GR 38 SAEA-T9

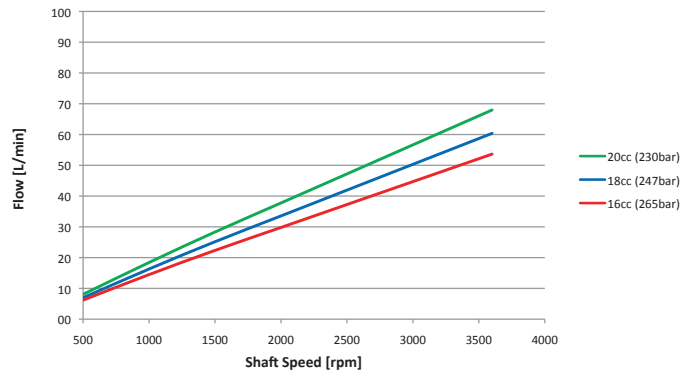

Power-torque performances @ 46 cSt

GR 28 - 4cc

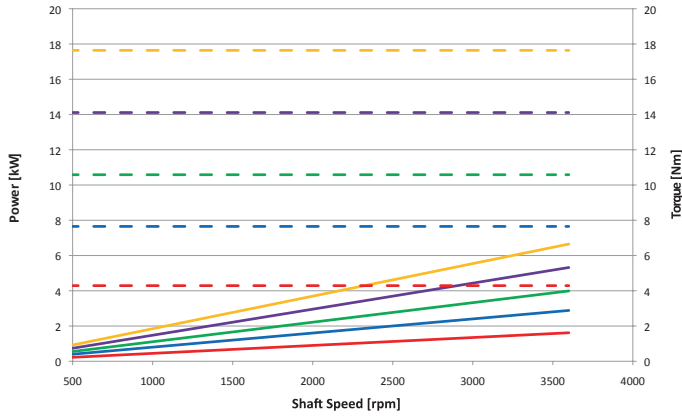

- Power (250 bar)
- Power (200 bar)
- Power (150 bar)
- Power (100 bar)
- Power (50 bar)
- - Torque (250 bar)
- - Torque (200 bar)
- - Torque (150 bar)
- - Torque (100 bar)
- - Torque (50 bar)

GR 28 - 6cc

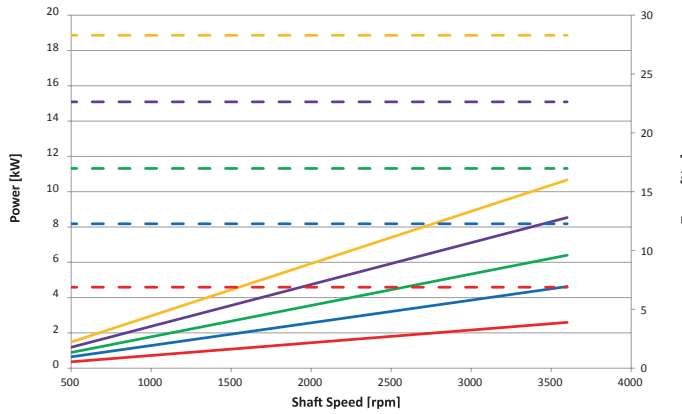

GR 28 - 8cc

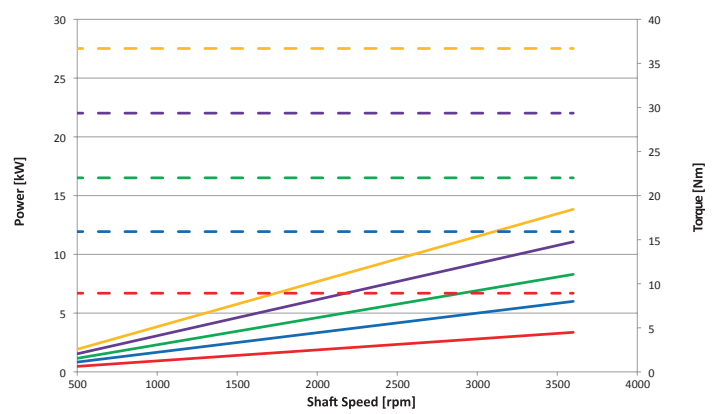

GR 28 - 10cc

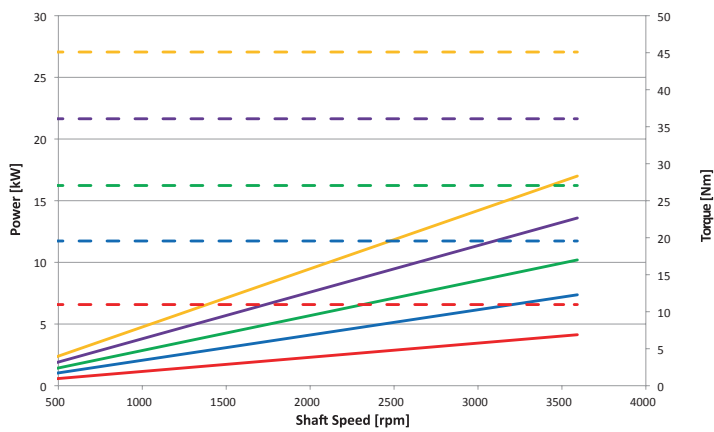

GR 28 - 13cc

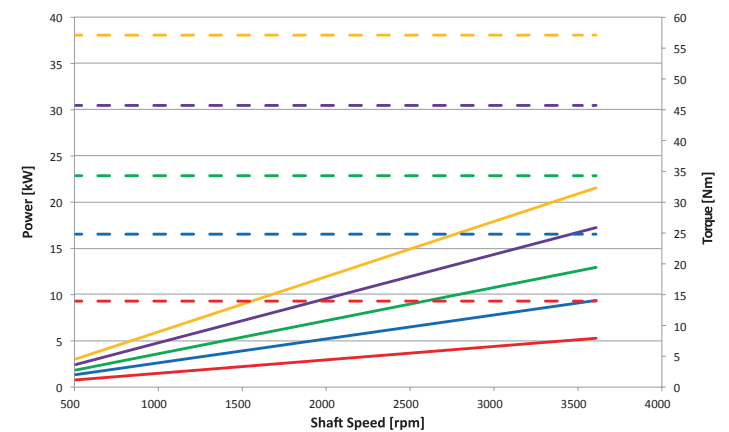

GR 33 - 10cc

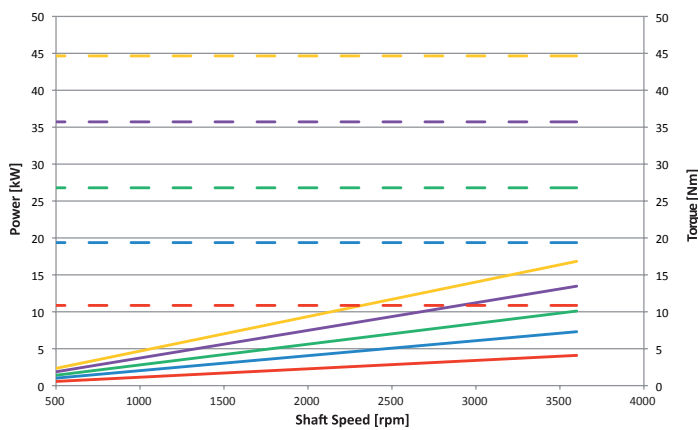

GR 33 - 13cc

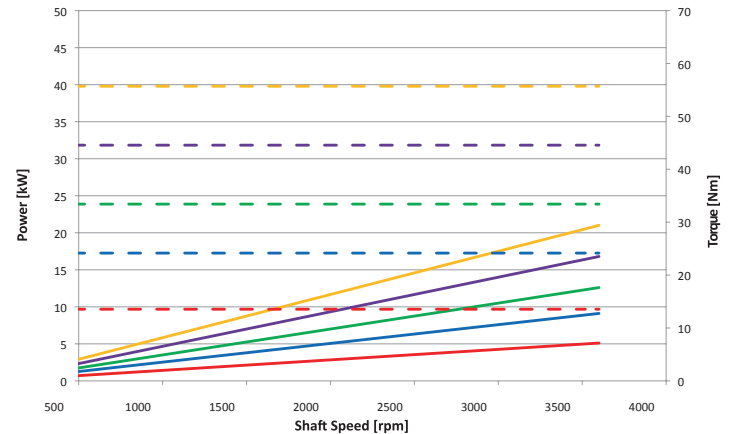

GR 33 - 15cc

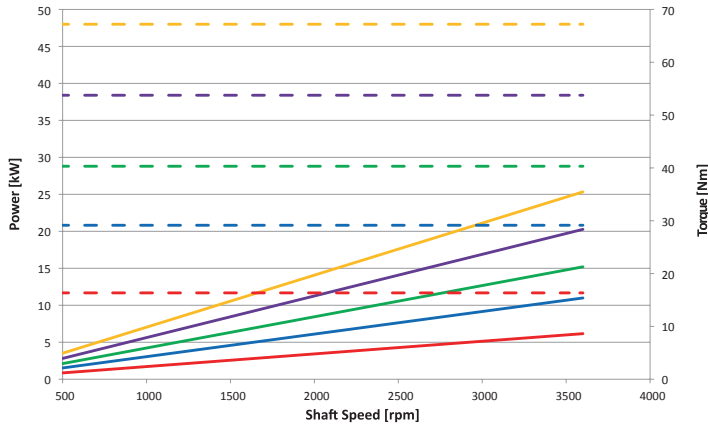

GR 33 - 18cc

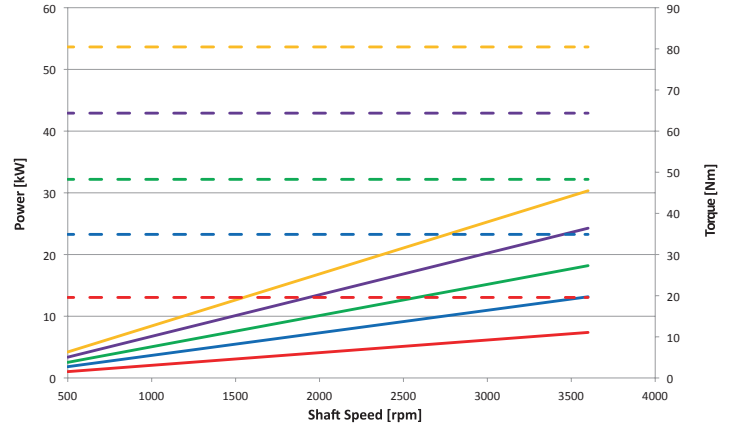

GR 38 - 16cc

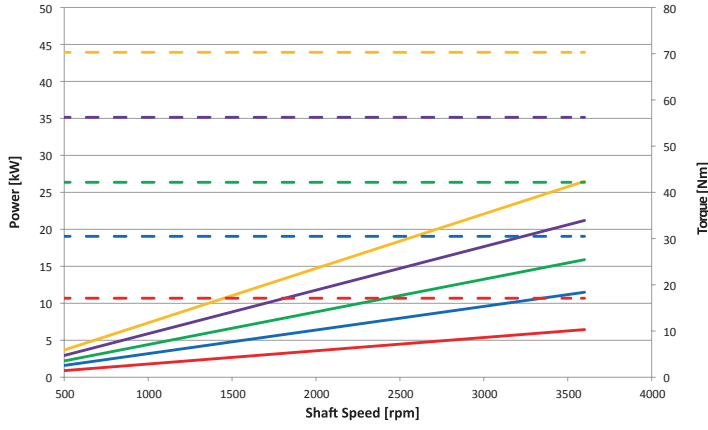

GR 38 - 18cc

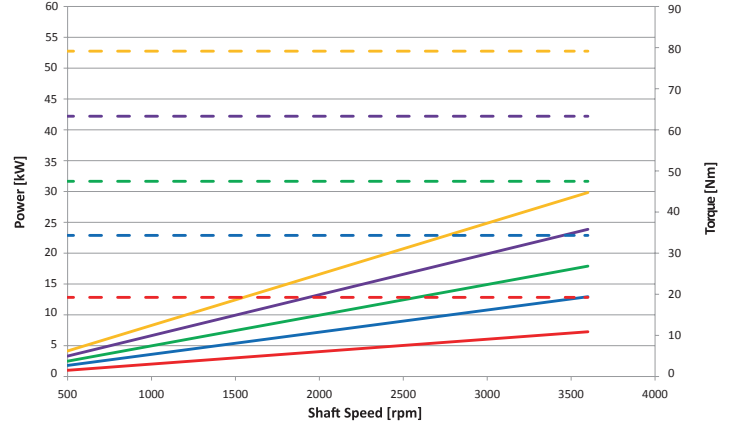

GR 38 - 20cc

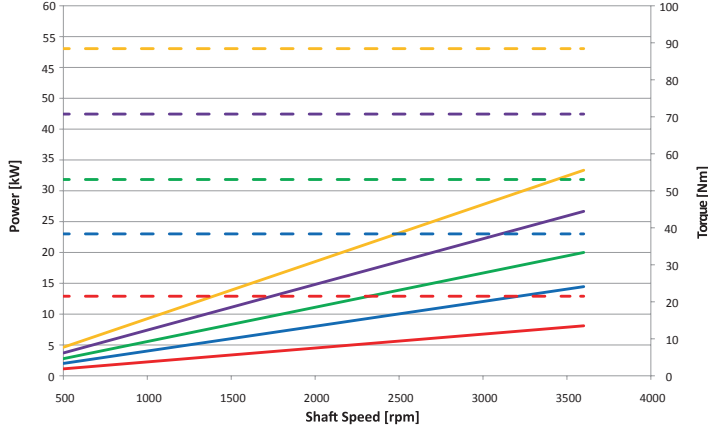

GR 38 - 22cc

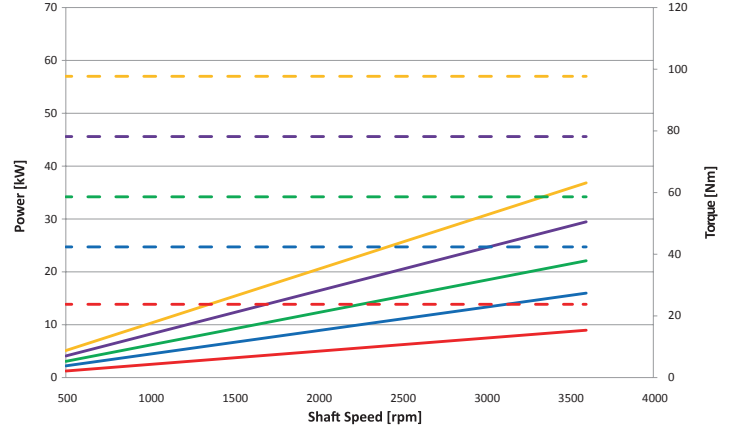

GR 38 - 25cc

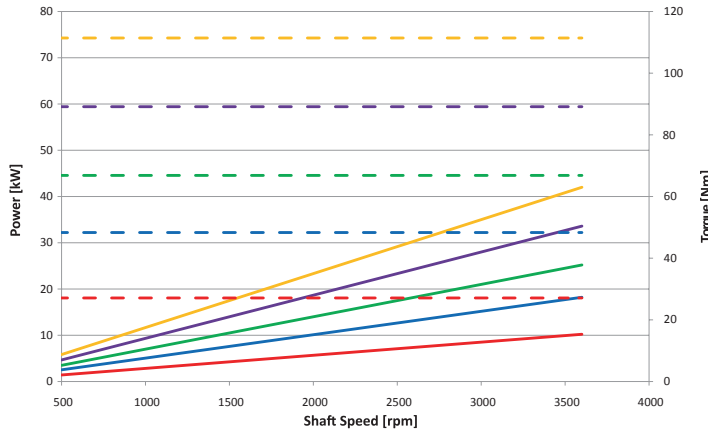

GR 38 - 28cc

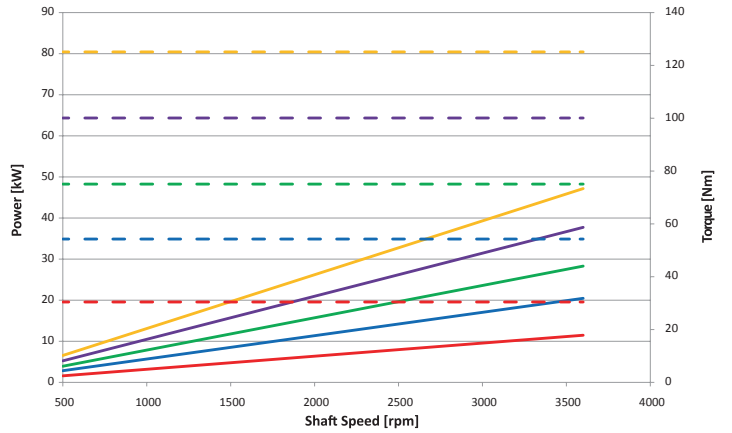

- Power (250 bar)
- Power (200 bar)
- Power (150 bar)
- Power (100 bar)
- Power (50 bar)
- - - Torque (250 bar)
- - - Torque (200 bar)
- - - Torque (150 bar)
- - - Torque (100 bar)
- - - Torque (50 bar)

GR 47 - 28cc

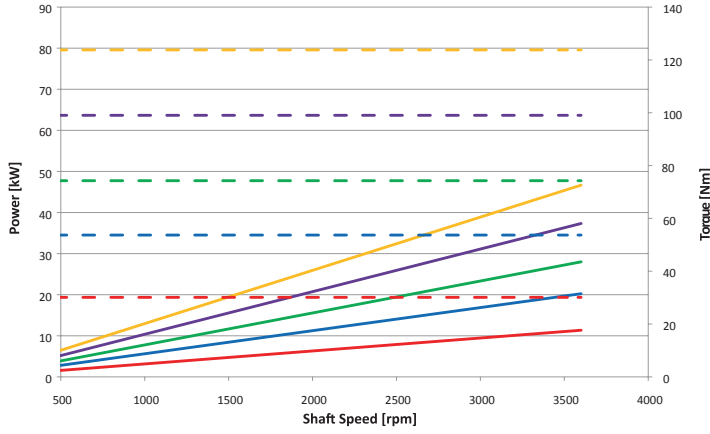

GR 47 - 32cc

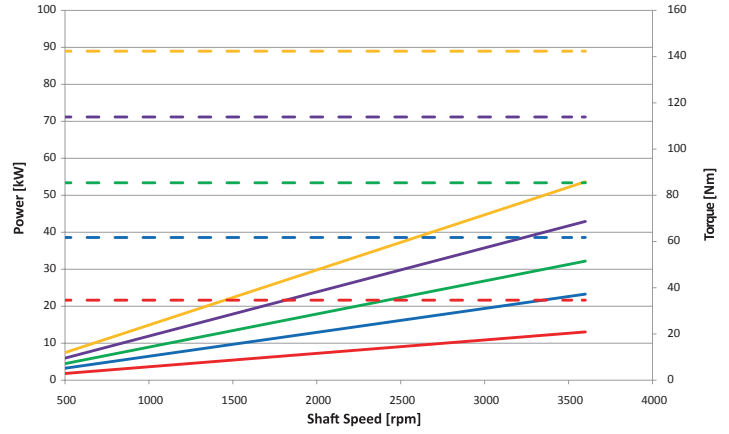

GR 47 - 36cc

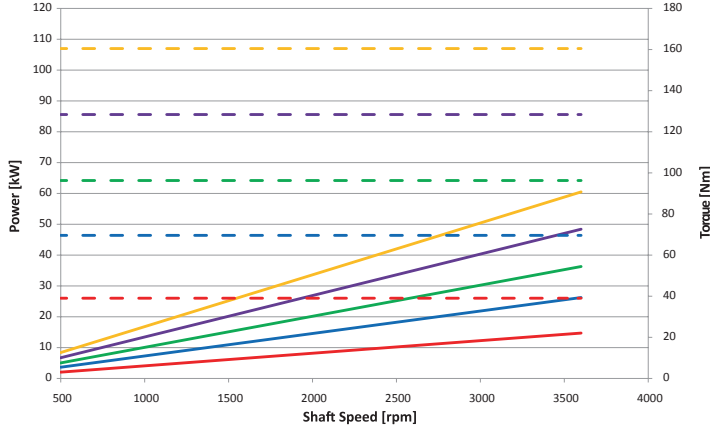

GR 47 - 40cc

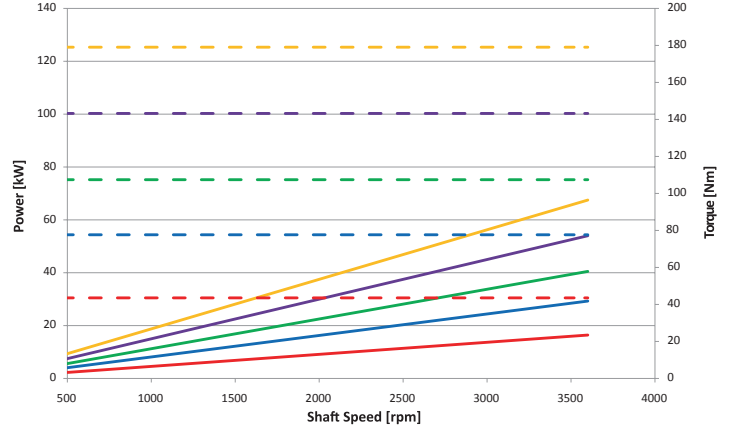

GR 47 - 45cc

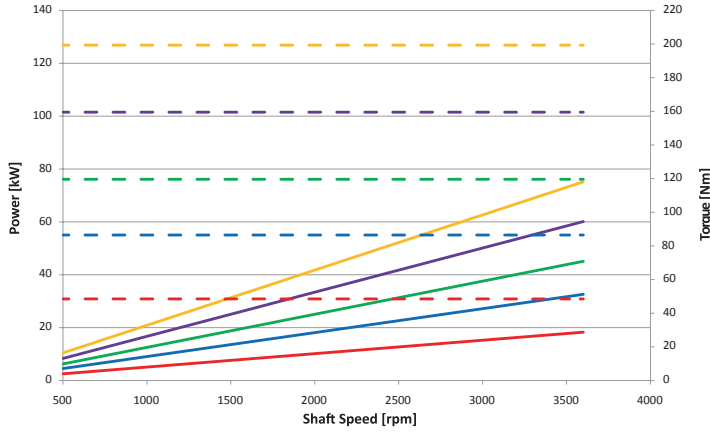

GR 47 - 50cc

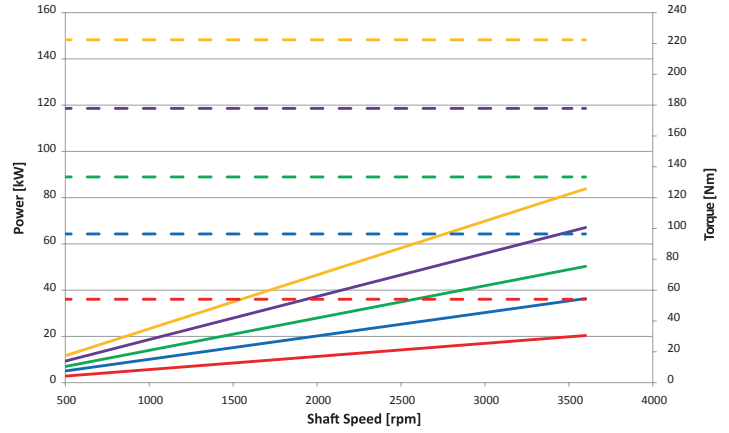

GR 55 - 50cc

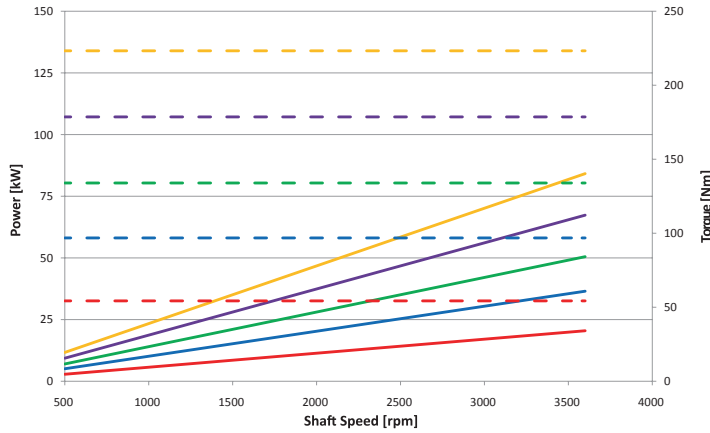

GR 55 - 63cc

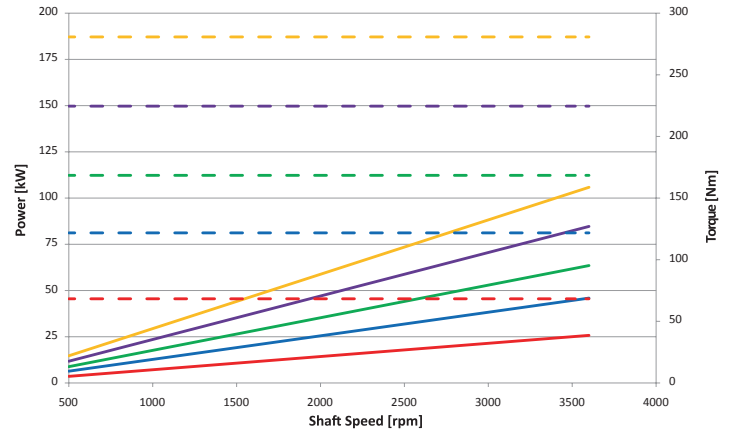

- Power (250 bar)
- Torque (250 bar)
- Power (200 bar)
- Torque (200 bar)
- Power (150 bar)
- Torque (150 bar)
- Power (100 bar)
- Torque (100 bar)
- Power (50 bar)
- Torque (50 bar)

GR 55 - 75cc

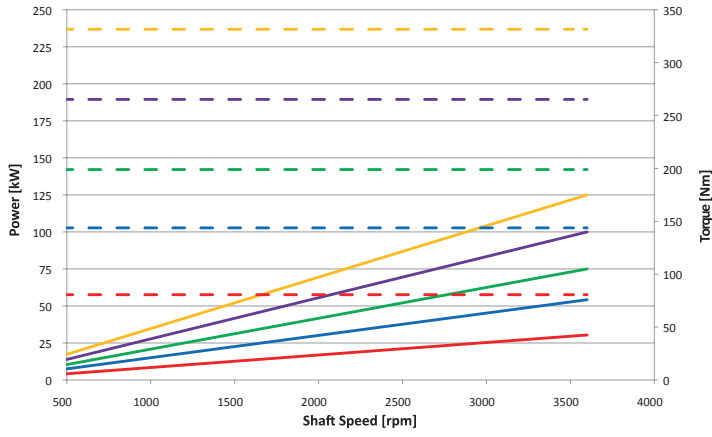

GR 55 - 90cc

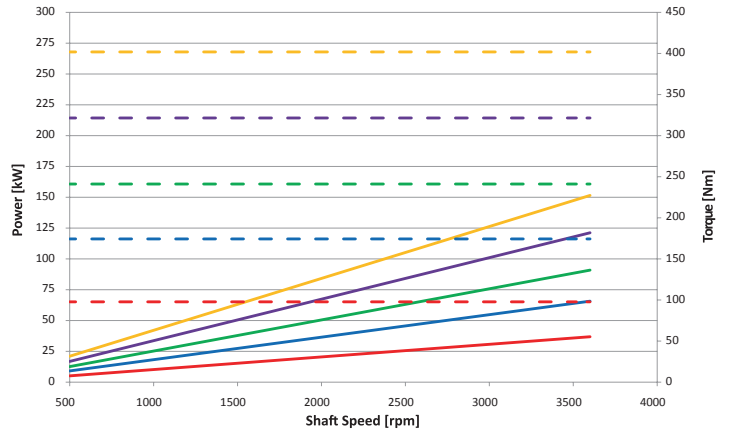

GR 72 - 94cc

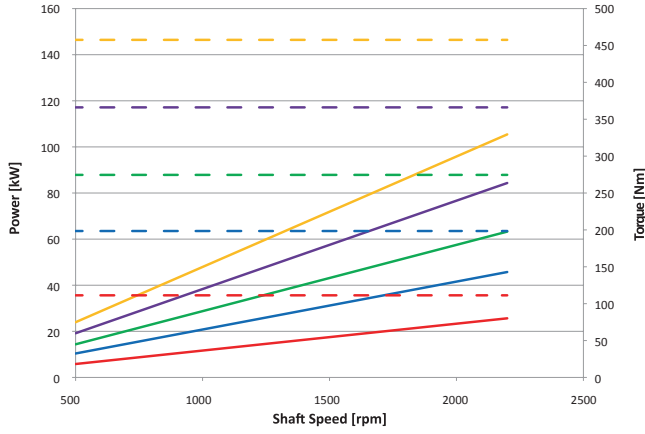

GR 72 - 101cc

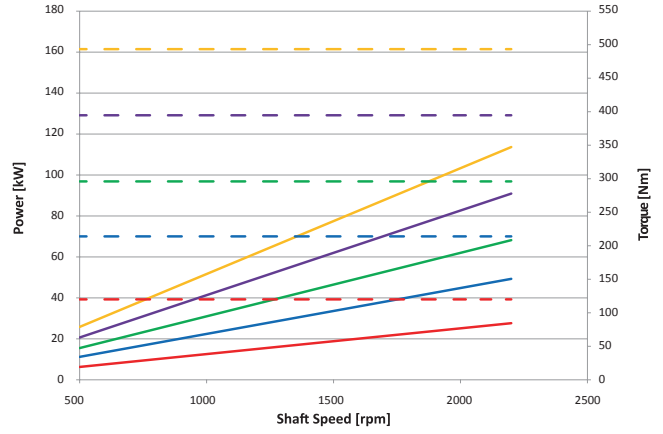

GR 72 - 125cc

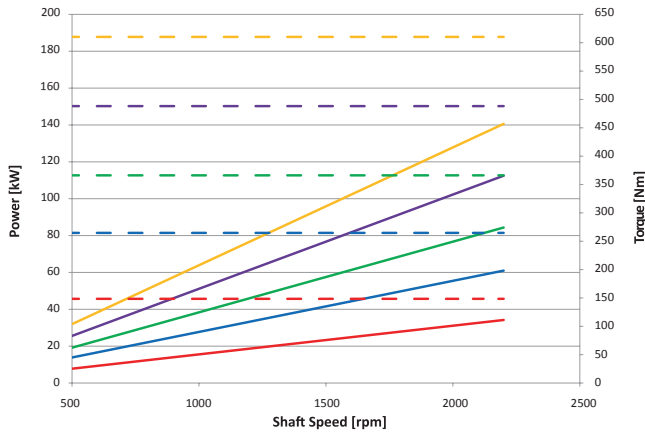

GR 72 - 150cc

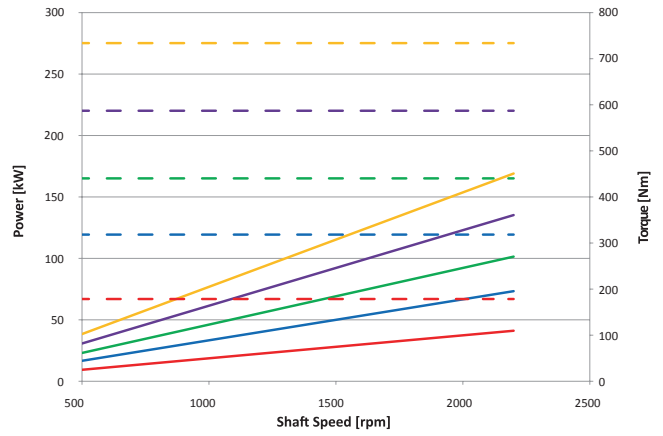

GR 72 - 175cc

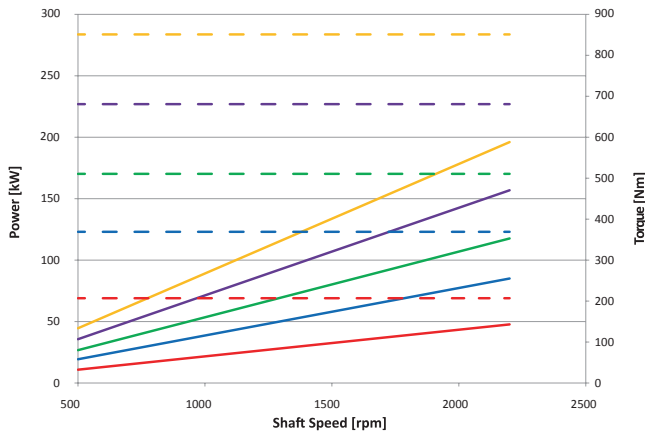

GR 72 - 200cc

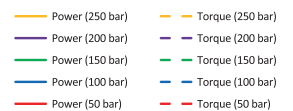
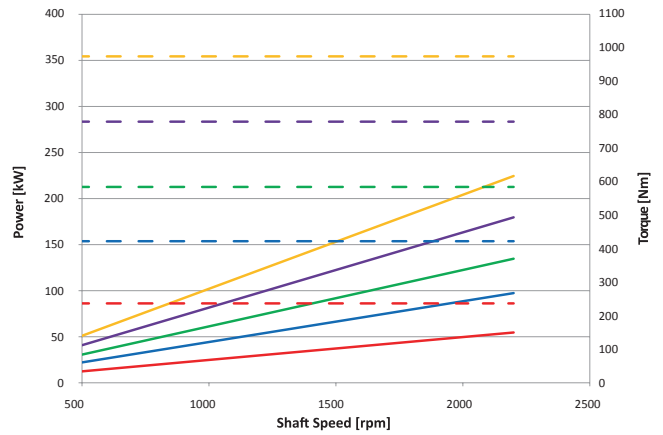

Tandem & multiple pumps / Pompe doppie e multiple

Continuum® pumps are suitable for multiple setups, whereby the drive shaft of the first pump is extended to a second and even a third **Continuum**® pump.

Each pump is connected to another by means of coupling. Each pump has its own suction port. Basically the technical specifications of single pumps apply also to multiple setups.

The maximum speed is determined by the highest pump speed rate in use.

In case of multiple setup configurations, it is recommended to use the largest displacement for the first pump.

The front pump may be equipped with different types of flange and shaft.

Ordering code / Codice ordine

Multiple setups / Pompe multiple

Type Tipo	Class Classe	Displacement Cilindrata	Flange & shaft Flangia & albero	Ports Porte	Type ^{2nd} stage Tipo 2° stadio	Displacement ^{2nd} stage Cilindrata 2° stadio	Ports Porte	Shaft seal Guarnizione albero	Rotation Rotazione
GR28	2V	004-006-008-010-013	F1AC3	G	GR28	004-006-008-010-013	G	Standard NBR (none)	Standard DX (none) 
GR33	2V	010-013-015-018	F2AC4	G-M	GR28				
					GR33	010-013-015-018			
GR38	2V	016-018-020-022-025-028	F2AC4	G-M	GR38	016-018-020-022-025-028	G-M		
					GR28	004-006-008-010-013	G		
					GR33	010-013-015-018	G-M		
GR47	2V	028-032-036-040-045-050	F3AC9 FSAEBAT13	O	GR28	004-006-008-010-013	G		
					GR33	010-013-015-018	G-M		
					GR38	016-018-020-022-025-028	G-M		
GR55	2V	050-063-075-090	FSAEBAT15	O	GR47	028-032-036-040-045-050	O		
					GR33	010-013-015-018	G-M		
					GR38	016-018-020-022-025-028	G-M		
					GR47	028-032-036-040-045-050	O		
GR72	2V	094-101-125-150-175-200-220	FSAEBAT23	M	GR55	050-063-075-090	O		
					GR47	028-032-036-040-045-050	O		
					GR72	094-101-125-150-175-200	M		

* Please Contact Settima for SX counter clockwise optional rotation.
Contattare Settima per rotazione SX opzionale.

DIRECTION OF ROTATION / SENSO DI ROTAZIONE

Continuum® pumps are available with right rotation as standard configuration and left rotation as optional configuration. Right hand rotation means that, when standing in front of the pump, with driving shaft towards to the observer, the pump is rotating clockwise (DX). The other way around with left hand rotation, counter clockwise (SX).

Le pompe **Continuum**® sono fornite con la configurazione standard di rotazione destra. Opzionale la rotazione sinistra. Con rotazione destra (DX) si intende che, guardando la pompa frontalmente, con l'albero conduttore sporgente verso il punto di osservazione, la rotazione sarà in senso orario, con il lato mandata sulla destra e il lato aspirazione sulla sinistra della pompa. Viceversa per quanto riguarda la rotazione sinistra (SX).

DX: Clockwise rotation / Rotazione destra

SX: Counter clockwise rotation / Rotazione sinistra

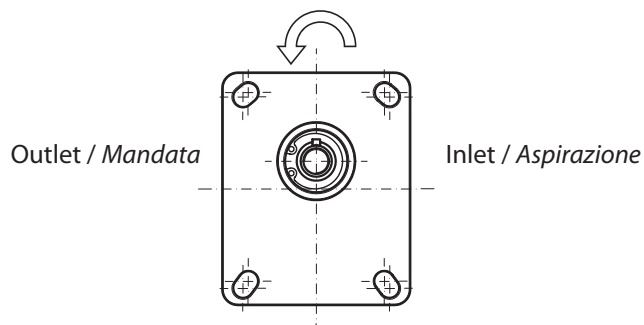
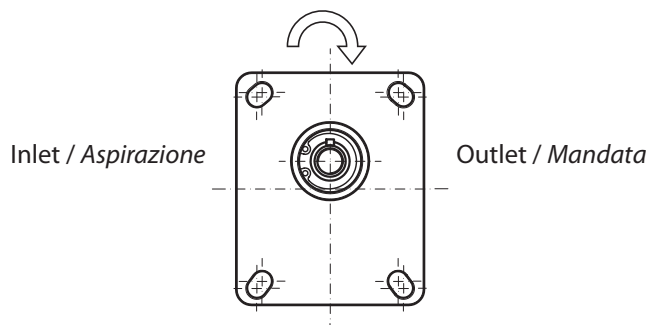

GR28 - Group 1 tandem pumps

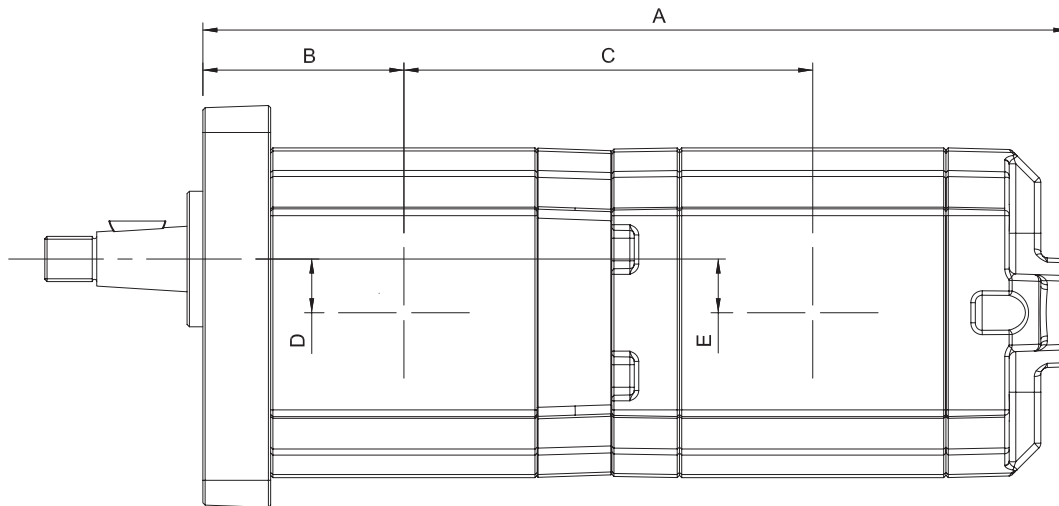

GR28 + GR28			2°				
			4	6	8	10	13
1°	4	A	191,50	-	-	-	-
		B	44,50	-	-	-	-
		C	90,50	-	-	-	-
		D	11,90	-	-	-	-
		E	11,90	-	-	-	-
	6	A	197,00	202,50	-	-	-
		B	47,25	47,25	-	-	-
		C	93,25	96,00	-	-	-
		D	11,90	11,90	-	-	-
		E	11,90	11,90	-	-	-
	8	A	202,00	207,50	212,50	-	-
		B	49,75	49,75	49,75	-	-
		C	95,75	98,50	101,00	-	-
		D	11,90	11,90	11,90	-	-
		E	11,90	11,90	11,90	-	-
	10	A	207,00	212,50	217,50	222,50	-
		B	52,25	52,25	52,25	52,25	-
		C	98,25	101,00	103,50	106,00	-
		D	11,90	11,90	11,90	11,90	-
		E	11,90	11,90	11,90	11,90	-
13	A	214,00	219,50	224,50	229,50	236,50	
	B	55,70	55,70	55,70	55,70	55,70	
	C	101,75	104,50	107,00	109,50	113,00	
	D	11,90	11,90	11,90	11,90	11,90	
	E	11,90	11,90	11,90	11,90	11,90	

Available flanges and shafts for GR28

Flange ed alberi disponibili per GR28: 1C3; 1K-G54; SAEA-AC

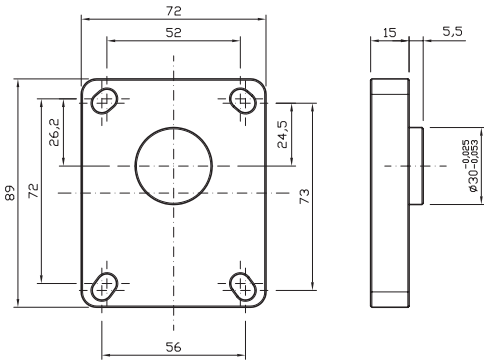

Type flange 1C3
Flangia tipo 1C3

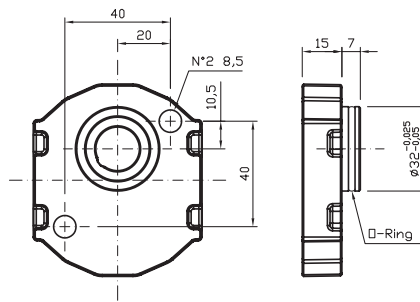

Type flange 1K-G54
Flangia tipo 1K-G54

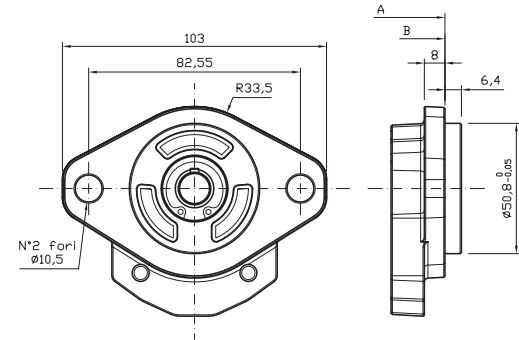

Type flange SAEA-AC
Flangia tipo SAEA-AC

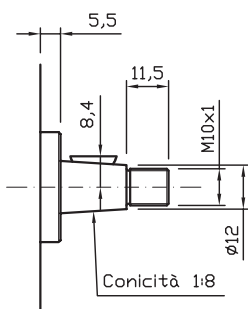

Type shaft 1C3
Albero tipo 1C3
Max torque / Coppia max: 100 Nm

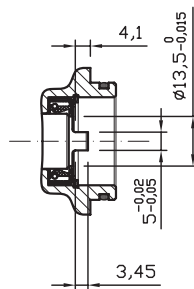

Type shaft 1K-G54
Albero tipo 1K-G54
Max torque / Coppia max: 50 Nm

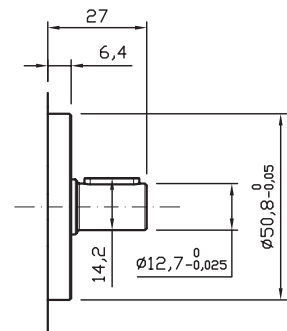

Type shaft SAEA-AC
Albero tipo SAEA-AC
Max torque / Coppia max: 60 Nm

GR33; GR38 - Groups 2 tandem pumps

GR33

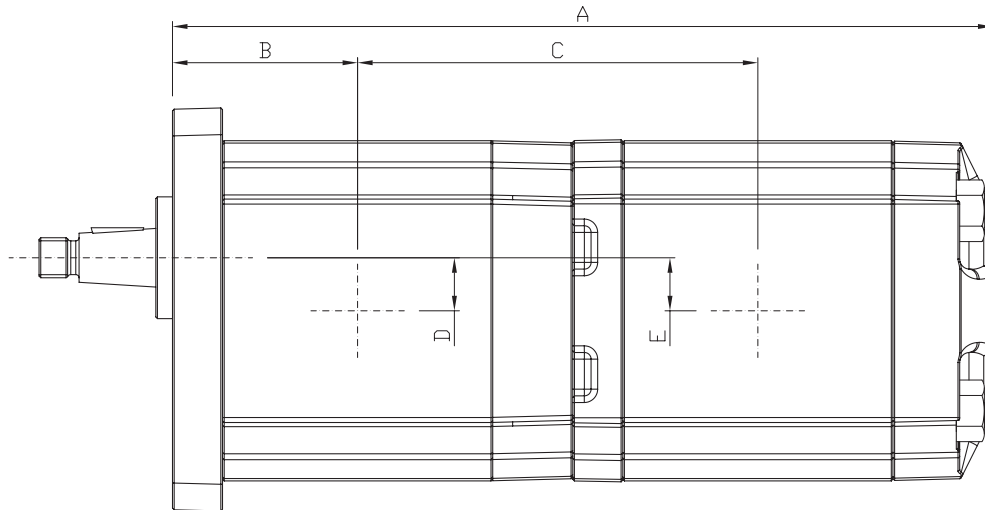

GR33 + GR28			2°				
			4	6	8	10	13
1°	10	A	216,50	222,00	227,00	232,00	239,00
		B	53,75	53,75	53,75	53,75	53,75
		C	16,25	109,00	111,50	114,00	117,50
		D	13,75	13,75	13,75	13,75	13,75
		E	11,90	11,90	11,90	11,90	11,90
	13	A	221,4	226,90	231,90	236,90	243,90
		B	56,20	56,20	56,20	56,20	56,20
		C	108,70	111,45	113,95	116,45	119,95
		D	13,75	13,75	13,75	13,75	13,75
		E	11,90	11,90	11,90	11,90	11,90
	15	A	226,40	231,90	236,90	241,90	248,90
		B	58,70	58,70	58,70	58,70	58,70
		C	111,20	113,95	116,45	118,95	122,45
		D	13,75	13,75	13,75	13,75	13,75
		E	11,90	11,90	11,90	11,90	11,90
	18	A	232,2	237,70	242,70	247,70	254,70
		B	61,60	61,60	61,60	61,60	61,60
		C	114,10	116,85	119,35	121,85	125,35
		D	13,75	13,75	13,75	13,75	13,75
		E	11,90	11,90	11,90	11,90	11,90

GR33 + GR33			2°			
			10	13	15	18
1°	10	A	236,00	-	-	-
		B	53,75	-	-	-
		C	113,50	-	-	-
		D	13,75	-	-	-
		E	13,75	-	-	-

	13	A	240,90	245,80	-	-
		B	56,20	56,20	-	-
		C	115,95	118,40	-	-
		D	13,75	13,75	-	-
		E	13,75	13,75	-	-
	15	A	245,90	250,80	255,80	-
		B	58,70	58,70	58,70	-
		C	118,45	120,90	123,40	-
		D	13,75	13,75	13,75	-
		E	13,75	13,75	13,75	-
	18	A	251,70	256,60	261,60	267,40
		B	61,60	61,60	61,60	61,60
		C	121,35	123,80	126,30	129,20
		D	13,75	13,75	13,75	13,75
		E	13,75	13,75	13,75	13,75

Available flanges and shafts for GR33

Flange ed alberi disponibili per GR33: 2C4; SAEA-AC; SAEA-T9; 2BK7-G

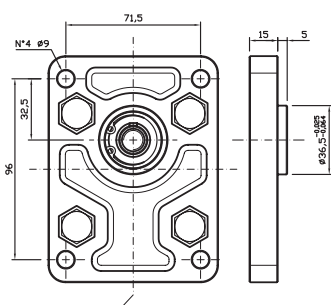

Type flange 2C4
Flangia tipo 2C4

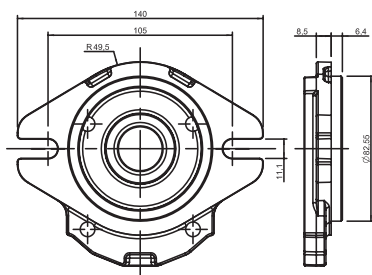

Type flange SAEA-AC
Flangia tipo SAEA-AC

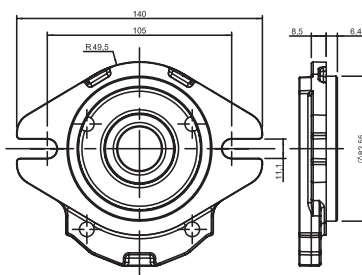

Type flange SAEA-T9
Flangia tipo SAEA-T9

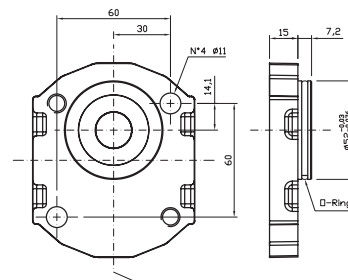

Type flange 2BK7-G
Flangia tipo 2BK7-G

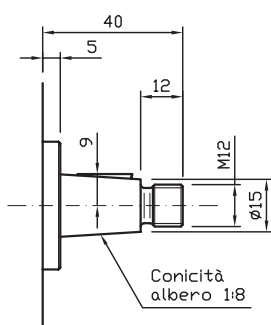

Type shaft 2C4
Albero tipo 2C4

Max torque / Coppia max: 210 Nm

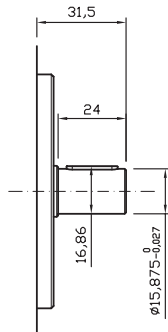

Type shaft SAEA-AC
Albero tipo SAEA-AC

Max torque / Coppia max: 140 Nm

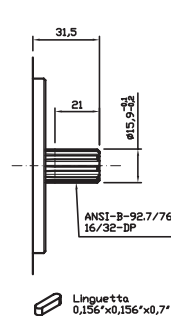

Type shaft SAEA-T9
Albero tipo SAEA-T9

Max torque / Coppia max: 190 Nm

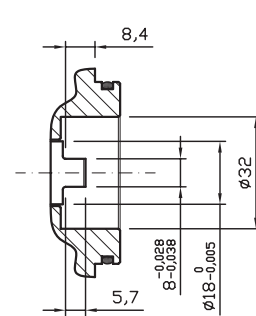

Type shaft 2BK7-G
Albero tipo 2BK7-G

Max torque / Coppia max: 110 Nm

GR38 + GR28			2°				
			4	6	8	10	13
1°	16	A	191,50	228,50	233,50	238,50	245,50
		B	44,50	55,50	55,50	55,50	55,50
		C	90,50	113,75	116,25	118,75	122,25
		D	11,90	15,90	15,90	15,90	15,90
		E	11,90	11,90	11,90	11,90	11,90
	18	A	226,00	231,50	236,50	241,50	248,50
		B	57,00	57,00	57,00	57,00	57,00
		C	112,50	115,25	117,75	120,25	123,75
		D	15,90	15,90	15,90	15,90	15,90
		E	11,90	11,90	11,90	11,90	11,90
	20	A	229,00	234,50	239,50	244,50	251,50
		B	58,50	58,50	58,50	58,50	58,50
		C	114,00	116,75	119,25	121,75	125,25
		D	15,90	15,90	15,90	15,90	15,90
		E	11,90	11,90	11,90	11,90	11,90
	22	A	232,00	237,50	242,50	247,5	254,50
		B	60,00	60,00	60,00	60,00	60,00
		C	115,50	118,25	120,75	123,25	126,75
		D	15,90	15,90	15,90	15,90	15,90
		E	11,90	11,90	11,90	11,90	11,90
	25	A	236,50	242,00	247,00	252,00	259,00
		B	62,25	62,25	62,25	62,25	62,25
		C	117,75	120,50	123,00	125,50	129,00
		D	15,90	15,90	15,90	15,90	15,90
		E	11,90	11,90	11,90	11,90	11,90
28	A	241,00	246,50	251,50	256,50	263,50	
	B	64,50	64,50	64,50	64,50	64,50	
	C	120,00	122,75	125,25	127,75	131,25	
	D	15,90	15,90	15,90	15,90	15,90	
	E	11,90	11,90	11,90	11,90	11,90	

GR38 + GR33			2°			
			10	13	15	18
1°	16	A	242,50	247,40	252,40	258,20
		B	55,50	55,50	55,50	55,50
		C	118,25	120,70	123,20	126,10
		D	15,90	15,90	15,90	15,90
		E	13,75	13,75	13,75	13,75

	18	A	245,50	250,40	255,40	261,20
		B	57,00	57,00	57,00	57,00
		C	119,75	122,20	124,70	127,60
		D	15,90	15,90	15,90	15,90
		E	13,75	13,75	13,75	13,75
	20	A	248,50	253,40	258,40	264,20
		B	58,50	58,50	58,50	58,50
		C	121,25	123,70	126,20	129,10
		D	15,90	15,90	15,90	15,90
		E	13,75	13,75	13,75	13,75
	22	A	251,50	256,40	261,40	267,20
		B	60,00	60,00	60,00	60,00
		C	122,75	125,20	127,70	130,60
		D	15,90	15,90	15,90	15,90
		E	13,75	13,75	13,75	13,75
	25	A	2560	260,90	265,90	271,70
		B	62,25	62,25	62,25	62,25
		C	1250	127,45	129,95	132,85
		D	15,90	15,90	15,90	15,90
		E	13,75	13,75	13,75	13,75
28	A	260,50	265,4	270,40	276,20	
	B	64,50	64,50	64,50	64,50	
	C	127,25	129,70	132,20	135,1 0	
	D	15,90	15,90	15,90	15,90	
	E	13,75	13,75	13,75	13,75	

GR38 + GR38			2°					
			16	18	20	22	25	28
1°	16	A	246,00	-	-	-	-	-
		B	55,50	-	-	-	-	-
		C	120,00	-	-	-	-	-
		D	15,90	-	-	-	-	-
		E	15,90	-	-	-	-	-
	18	A	249,00	252,00	-	-	-	-
		B	57,00	57,00	-	-	-	-
		C	121,50	123,00	-	-	-	-
		D	15,90	15,90	-	-	-	-
		E	15,90	15,90	-	-	-	-
	20	A	252,00	255,00	258,00	-	-	-
		B	58,50	58,50	58,50	-	-	-
		C	123,00	124,50	126,00	-	-	-
		D	15,90	15,90	15,90	-	-	-
		E	15,90	15,90	15,90	-	-	-

	22	A	255,00	258,00	261,00	264,00	-	-
		B	60,00	60,00	60,00	60,00	-	-
		C	124,50	126,00	127,50	129,00	-	-
		D	15,90	15,90	15,90	15,90	-	-
		E	15,90	15,90	15,90	15,90	-	-
	25	A	259,50	262,50	265,50	268,50	273,00	-
		B	62,25	62,25	62,25	62,25	62,25	-
		C	126,75	128,25	129,75	131,25	133,50	-
		D	15,90	15,90	15,90	15,90	15,90	-
		E	15,90	15,90	15,90	15,90	15,90	-
	28	A	264,00	267,00	270,00	273,00	277,50	282,00
		B	64,50	64,50	64,50	64,50	64,50	64,50
		C	129,00	130,50	132,00	133,50	135,75	138,00
		D	15,90	15,90	15,90	15,90	15,90	15,90
		E	15,90	15,90	15,90	15,90	15,90	15,90

Available flanges and shafts for GR38

Flange ed alberi disponibili per GR38: 2-BK7 G; SAEA-T11; SAEA-AC; 2C4

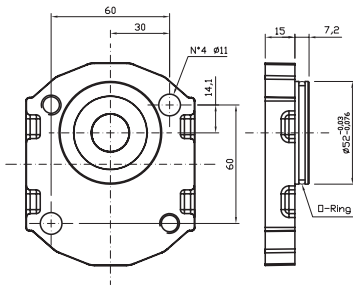

Type flange 2BK7-G
Flangia tipo 2BK7-G

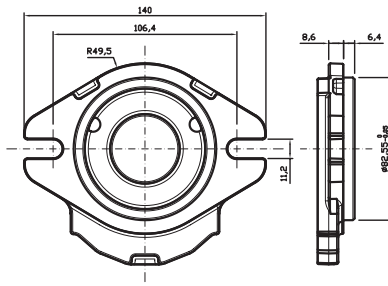

Type flange SAEA-AT11
Flangia tipo SAEA-AT11

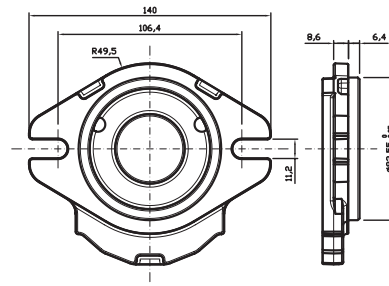

Type flange SAEA-AC
Flangia tipo SAEA-AC

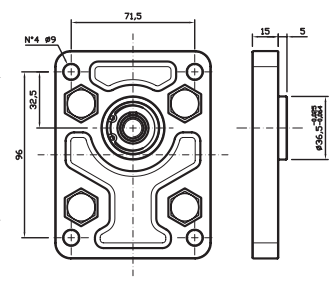

Type flange 2C4
Flangia tipo 2C4

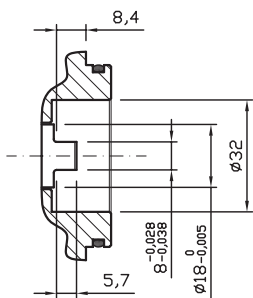

Type shaft 2BK7-G
Albero tipo 2BK7-G
Max torque/Coppia max: 110 Nm

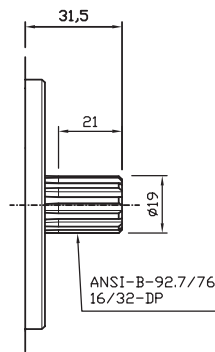

Type shaft SAEA-AT11
Albero tipo SAEA-AT11
Max torque/Coppia max: 210 Nm

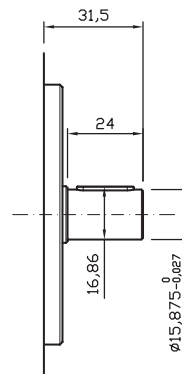

Type shaft SAEA-AC
Albero tipo SAEA-AC
Max torque/Coppia max: 140 Nm

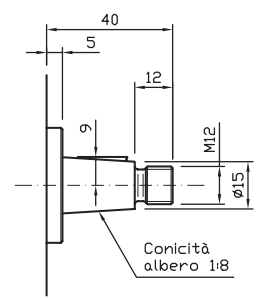

Type shaft 2C4
Albero tipo 2C4
Max torque/Coppia max: 210 Nm

GR47 - Group 3 tandem pumps

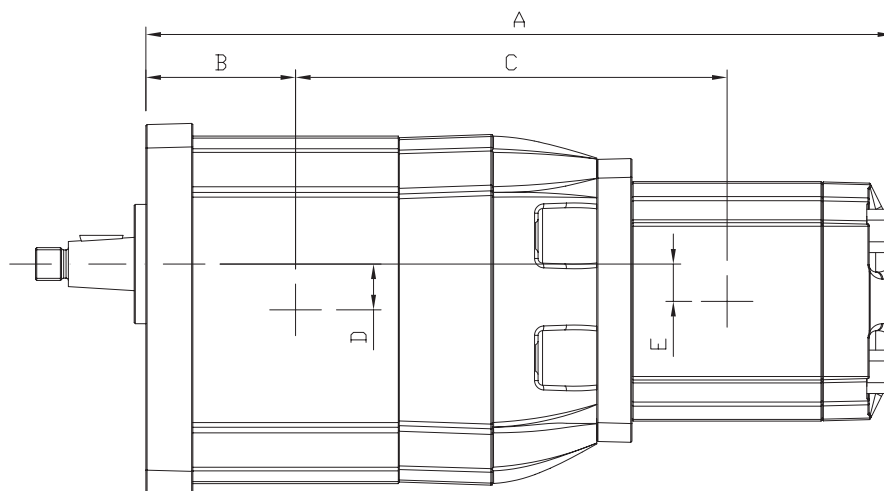

GR47 + GR28		2°					
		4	6	8	10	13	
1°	28	A	292,00	297,50	302,50	307,50	314,40
		B	67,50	67,50	67,50	67,50	67,50
		C	168,00	170,75	173,25	175,75	179,25
		D	19,50	19,50	19,50	19,50	19,50
		E	11,90	11,90	11,90	11,90	11,90
	32	A	296,00	301,50	306,50	311,50	318,40
		B	69,50	69,50	69,50	69,50	69,50
		C	170,00	172,75	175,25	177,75	181,25
		D	19,50	19,50	19,50	19,50	19,50
		E	11,90	11,90	11,90	11,90	11,90
	36	A	300,00	305,50	310,50	315,50	322,40
		B	71,50	71,50	71,50	71,50	71,50
		C	136,00	138,75	141,25	143,75	147,20
		D	19,50	19,50	19,50	19,50	19,50
		E	11,90	11,90	11,90	11,90	11,90
	40	A	304,00	309,50	314,50	319,50	326,40
		B	73,50	73,50	73,50	73,50	73,50
		C	174,00	176,75	179,25	181,75	185,25
		D	19,50	19,50	19,50	19,50	19,50
		E	11,90	11,90	11,90	11,90	11,90
45	A	308,50	314,00	319,00	324,00	330,90	
	B	75,75	75,75	75,75	75,75	75,75	
	C	140,25	143,00	145,50	148,00	151,45	
	D	19,50	19,50	19,50	19,50	19,50	
	E	11,90	11,90	11,90	11,90	11,90	
50	A	313,50	319,00	324,00	329,00	335,90	
	B	78,25	78,25	78,25	78,25	78,25	
	C	178,75	181,50	184,00	186,50	190,00	
	D	19,50	19,50	19,50	19,50	19,50	
	E	11,90	11,90	11,90	11,90	11,90	

GR47 + GR33			2°			
			10	13	15	18
1°	28	A	322,00	326,90	331,90	337,70
		B	67,50	67,50	67,50	67,50
		C	185,25	188,20	190,70	193,60
		D	19,50	19,50	19,50	19,50
		E	13,75	13,75	13,75	13,75
	32	A	326,00	330,90	335,90	341,70
		B	69,50	69,50	69,50	69,50
		C	187,25	190,20	192,70	195,60
		D	19,50	19,50	19,50	19,50
		E	13,75	13,75	13,75	13,75
	36	A	330,00	334,90	339,90	345,70
		B	71,50	71,50	71,50	71,50
		C	189,75	192,20	194,70	197,60
		D	19,50	19,50	19,50	19,50
		E	13,75	13,75	13,75	13,75
	40	A	334,00	338,90	343,90	349,70
		B	73,50	73,50	73,50	73,50
		C	191,75	194,20	196,70	199,60
		D	19,50	19,50	19,50	19,50
		E	13,75	13,75	13,75	13,75
	45	A	338,50	343,40	348,40	354,20
		B	75,75	75,75	75,75	75,75
		C	194,00	196,45	198,95	201,85
		D	19,50	19,50	19,50	19,50
		E	13,75	13,75	13,75	13,75
50	A	343,50	348,40	353,40	359,20	
	B	78,25	78,25	78,25	78,25	
	C	196,50	198,95	201,45	204,35	
	D	19,50	19,50	19,50	19,50	
	E	13,75	13,75	13,75	13,75	

GR47 + GR38			2°					
			16	18	20	22	25	28
1°	28	A	325,50	328,50	331,50	334,50	339,00	343,50
		B	67,50	67,50	67,50	67,50	67,50	67,50
		C	187,50	189,00	190,50	192,00	194,25	196,50
		D	19,50	19,50	19,50	19,50	19,50	19,50
		E	15,90	15,90	15,90	15,90	15,90	15,90

	32	A	329,50	332,50	335,50	338,50	343,00	347,50
		B	69,50	69,50	69,50	69,50	69,50	69,50
		C	189,50	191,00	192,50	194,00	196,25	154,00
		D	19,50	19,50	19,50	19,50	19,50	19,50
		E	15,90	15,90	15,90	15,90	15,90	15,90
	36	A	333,50	336,50	339,50	342,50	347,00	351,50
		B	71,50	71,50	71,50	71,50	71,50	71,50
		C	191,50	193,00	194,50	196,00	198,25	200,50
		D	19,50	19,50	19,50	19,50	19,50	19,50
		E	15,90	15,90	15,90	15,90	15,90	15,90
	40	A	337,50	340,50	343,50	346,50	351,00	355,50
		B	73,50	73,50	73,50	73,50	73,50	73,50
		C	193,50	195,00	196,50	198,00	200,25	202,50
		D	19,50	19,50	19,50	19,50	19,50	19,50
		E	15,90	15,90	15,90	15,90	15,90	15,90
	45	A	342,00	345,00	348,00	351,00	355,50	360,00
		B	75,75	75,75	75,75	75,75	75,75	75,75
		C	195,75	197,25	198,75	200,25	202,50	204,75
		D	19,50	19,50	19,50	19,50	19,50	19,50
		E	15,90	15,90	15,90	15,90	15,90	15,90
50	A	347,00	350,00	353,00	356,00	360,5	365,00	
	B	78,25	78,25	78,25	78,25	78,25	78,25	
	C	198,25	199,75	201,25	202,75	205,00	207,25	
	D	19,50	19,50	19,50	19,50	19,50	19,50	
	E	15,90	15,90	15,90	15,90	15,90	15,90	

GR47 + GR47			2°					
			28	32	36	40	45	50
1°	28	A	351,00	-	-	-	-	-
		B	67,50	-	-	-	-	-
		C	201,00	-	-	-	-	-
		D	19,50	-	-	-	-	-
		E	19,50	-	-	-	-	-
	32	A	356,50	360,50	-	--	-	-
		B	69,50	69,50	-	-	-	-
		C	203,00	205,00	-	-	-	-
		D	19,50	19,50	-	-	-	-
		E	19,50	19,50	-	-	-	-
	36	A	360,50	364,50	368,50	-	-	-
		B	71,50	71,50	71,50	-	-	-
		C	205,00	207,00	209,00	-	-	-
		D	19,50	19,50	19,50	-	-	-
		E	19,50	19,50	19,50	-	-	-

	40	A	364,50	368,50	372,50	376,50	-	-
		B	73,50	73,50	73,50	73,50	-	-
		C	207,00	209,00	211,00	213,00	-	-
		D	19,50	19,50	19,50	19,50	-	-
		E	19,50	19,50	19,50	19,50	-	-
	45	A	369,00	373,00	377,00	381,00	385,50	-
		B	75,75	75,75	75,75	75,75	75,75	-
		C	209,25	211,25	213,25	215,25	217,50	-
		D	19,50	19,50	19,50	19,50	19,50	-
		E	19,50	19,50	19,50	19,50	19,50	-
	50	A	374,00	378,00	382,00	386,00	390,50	395,50
		B	78,25	78,25	78,25	78,25	78,25	78,25
		C	211,75	213,75	215,75	217,75	220,00	222,50
		D	19,50	19,50	19,50	19,50	19,50	19,50
		E	19,50	19,50	19,50	19,50	19,50	19,50

Available flanges and shafts for GR47

Flange ed alberi disponibili per GR47: 3-C9; SAEB-AC; SAEB-T13

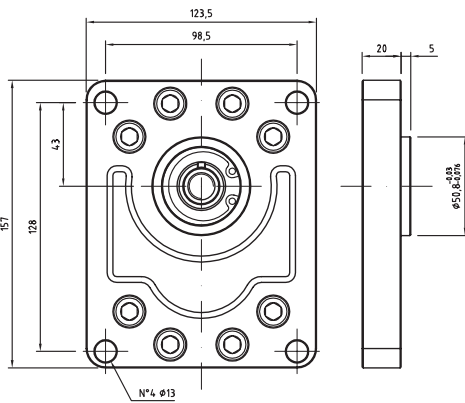

Type flange 3-C9
Flangia tipo 3-C9

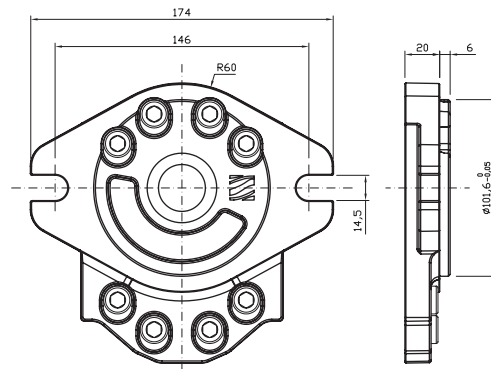

Type flange SAEB-AC
Flangia tipo SAEB-AC

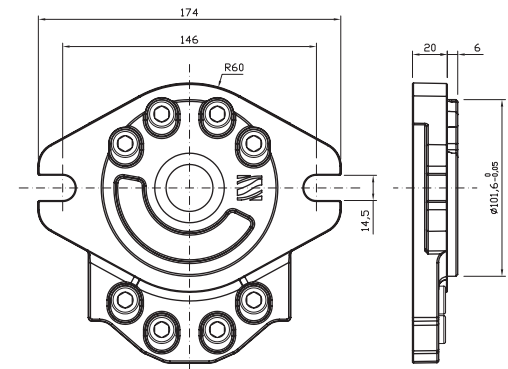

Type flange SAEB-T13
Flangia tipo SAEB-T13

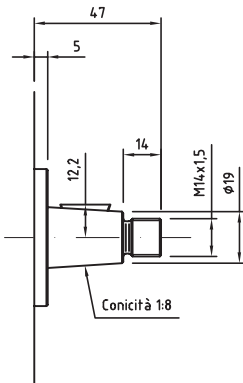

Type shaft 3-C9
Albero tipo 3-C9
Max torque / Coppia max: 320 Nm

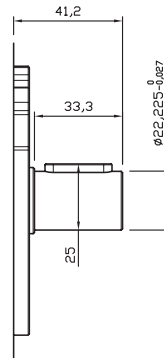

Type shaft SAEB-AC
Albero tipo SAEB-AC
Max torque / Coppia max: 450 Nm

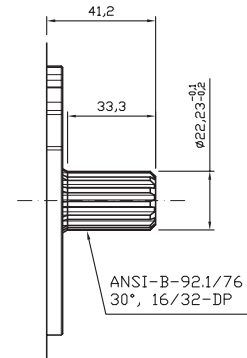

Type shaft SAEB-T13
Albero tipo SAEB-T13
Max torque / Coppia max: 600 Nm

GR55 - Group 4 tandem pumps

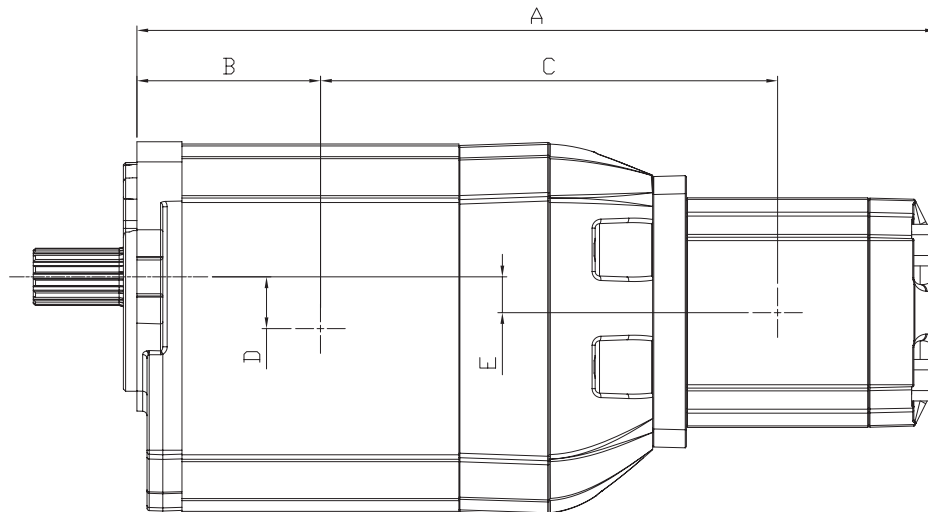

GR55 + GR28			2°				
			4	6	8	10	13
1°	50	A	323,00	328,50	333,50	338,50	345,40
		B	81,50	81,50	81,50	81,50	81,50
		C	185,00	187,75	190,25	192,75	196,25
		D	23,00	23,00	23,00	23,00	23,00
		E	11,90	11,90	11,90	11,90	11,90
	63	A	332,00	337,50	342,50	347,50	354,40
		B	86,00	86,00	86,00	86,00	86,00
		C	246,00	251,50	256,50	261,50	268,50
		D	23,00	23,00	23,00	23,00	23,00
		E	11,90	11,90	11,90	11,90	11,90
	75	A	340,00	345,50	350,50	355,50	362,40
		B	90,00	90,00	90,00	90,00	90,00
		C	193,50	196,25	198,75	201,25	204,75
		D	23,00	23,00	23,00	23,00	23,00
		E	11,90	11,90	11,90	11,90	11,90
	90	A	351,00	356,50	361,50	366,50	373,40
		B	95,50	95,50	95,50	95,50	95,50
		C	199,00	201,75	204,25	206,75	210,25
		D	23,00	23,00	23,00	23,00	23,00
		E	11,90	11,90	11,90	11,90	11,90

GR55 + GR33			2°			
			10	13	15	18
1°	50	A	351,50	356,40	361,40	367,20
		B	81,50	81,50	81,50	81,50
		C	201,25	203,70	206,20	209,10
		D	23,00	23,00	23,00	23,00
		E	13,75	13,75	13,75	13,75

	63	A	360,50	365,40	370,40	376,20
		B	86,00	86,00	86,00	86,00
		C	274,50	279,40	284,40	290,20
		D	23,00	23,00	23,00	23,00
		E	13,75	13,75	13,75	13,75
	75	A	368,50	373,40	378,40	384,20
		B	90,00	90,00	90,00	90,00
		C	209,75	212,20	214,70	217,60
		D	23,00	23,00	23,00	23,00
		E	13,75	13,75	13,75	13,75
	90	A	379,50	384,40	389,40	395,20
		B	95,50	95,50	95,50	95,50
		C	215,25	217,70	220,0	223,10
		D	23,00	23,00	23,00	23,00
		E	13,75	13,75	13,75	13,75

GR55 + GR33			2°			
			10	13	15	18
1°	50	A	351,50	356,40	361,40	367,20
		B	81,50	81,50	81,50	81,50
		C	201,25	203,70	206,20	209,10
		D	23,00	23,00	23,00	23,00
		E	13,75	13,75	13,75	13,75
	63	A	360,50	365,40	370,40	376,20
		B	86,00	86,00	86,00	86,00
		C	274,50	279,40	284,40	290,20
		D	23,00	23,00	23,00	23,00
		E	13,75	13,75	13,75	13,75
	75	A	368,50	373,40	378,40	384,20
		B	90,00	90,00	90,00	90,00
		C	209,75	212,20	214,70	217,60
		D	23,00	23,00	23,00	23,00
		E	13,75	13,75	13,75	13,75
	90	A	379,50	384,40	389,40	395,20
		B	95,50	95,50	95,50	95,50
		C	215,25	217,70	220,20	223,10
		D	23,00	23,00	23,00	23,00
		E	13,75	13,75	13,75	13,75

GR55 + GR38			2°					
			16	18	20	22	25	28
1°	50	A	355,00	358,00	361,00	364,00	368,50	373,00
		B	81,50	81,50	81,50	81,50	81,50	81,50
		C	203,00	204,50	206,00	207,50	209,75	212,00
		D	23,00	23,00	23,00	23,00	23,00	23,00
		E	15,90	15,90	15,90	15,90	15,90	15,90

	63	A	364,00	367,00	370,00	373,00	377,50	382,00
		B	86,00	86,00	86,00	86,00	86,00	86,00
		C	278,00	281,00	284,00	287,00	291,50	296,00
		D	23,00	23,00	23,00	23,00	23,00	23,00
		E	15,90	15,90	15,90	15,90	15,90	15,90
	75	A	372,00	375,00	378,00	381,00	385,50	390,00
		B	90,00	90,00	90,00	90,00	90,00	90,00
		C	211,50	213,00	214,50	216,00	218,25	220,50
		D	23,00	23,00	23,00	23,00	23,00	23,00
		E	15,90	15,90	15,90	15,90	15,90	15,90
	90	A	383,00	386,00	389,00	392,00	396,50	401,00
		B	95,50	95,50	95,50	95,50	95,50	95,50
		C	217,00	218,50	220,00	221,50	223,75	226,00
		D	23,00	23,00	23,00	23,00	23,00	23,00
		E	15,90	15,90	15,90	15,90	15,90	15,90

GR55 + GR47			2°					
			28	32	36	40	45	50
1°	50	A	387,00	391,00	395,00	400,50	403,50	408,50
		B	81,50	81,50	81,50	81,50	81,50	81,50
		C	223,00	225,00	227,00	229,00	231,25	233,75
		D	23,00	23,00	23,00	23,00	23,00	23,00
		E	19,50	19,50	19,50	19,50	19,50	19,50
	63	A	396,00	400,00	404,00	408,00	412,50	417,50
		B	86,00	86,00	86,00	86,00	86,00	86,00
		C	310,00	314,00	318,00	322,00	326,50	331,50
		D	23,00	23,00	23,00	23,00	23,00	23,00
		E	19,50	19,50	19,50	19,50	19,50	19,50
	75	A	404,00	408,00	412,00	416,00	420,50	425,50
		B	90,00	90,00	90,00	90,00	90,00	90,00
		C	231,50	233,50	235,50	237,50	239,75	242,25
		D	23,00	23,00	23,00	23,00	23,00	23,00
		E	19,50	19,50	19,50	19,50	19,50	19,50
	90	A	415,00	418,00	423,00	427,00	431,50	436,50
		B	95,50	95,50	95,50	95,50	95,50	95,50
		C	237,00	239,00	241,00	243,00	245,25	247,75
		D	23,00	23,00	23,00	23,00	23,00	23,00
		E	19,50	19,50	19,50	19,50	19,50	19,50

GR55 + GR55			2°			
			50	63	75	90
1°	50	A	415,00	-	-	-
		B	81,50	-	-	-
		C	237,00	-	-	-
		D	23,00	-	-	-
		E	19,50	-	-	-

	63	A	424,00	433,00	-	-
		B	86,00	86,00	-	-
		C	338,00	347,00	-	-
		D	23,00	23,00	-	-
		E	19,50	19,50	-	-
	75	A	432,00	441,00	449,00	-
		B	90,00	90,00	90,00	-
		C	245,50	250,00	254,00	-
		D	23,00	23,00	23,00	-
		E	19,50	19,50	19,50	-
	90	A	443,00	452,00	460,00	471,00
		B	95,50	95,50	95,50	95,50
		C	251,00	255,50	259,50	265,00
		D	23,00	23,00	23,00	23,00
		E	19,50	19,50	19,50	19,50

Available flanges and shafts for GR55

Flange ed alberi disponibili per GR55: SAEB-AC; SAEB-T15

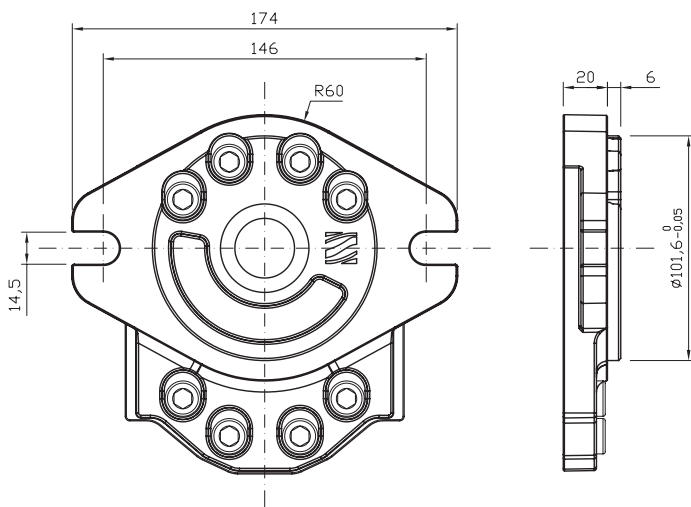

Type flange SAEB-AC
Flangia tipo SAEB-AC

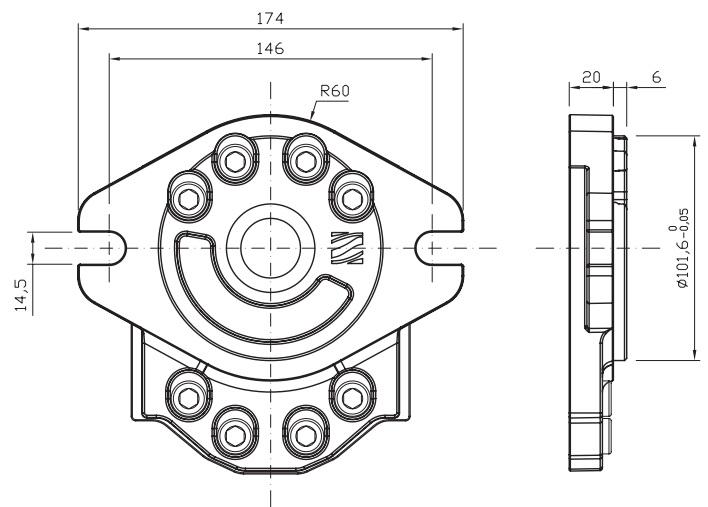

Type flange SAEB-T15
Flangia tipo SAEB-T15

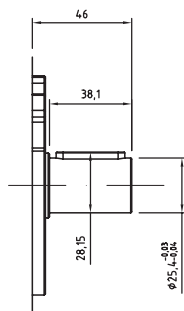

Type shaft SAEB-AC
Albero tipo SAEB-AC
Max torque / Coppia max: 550 Nm

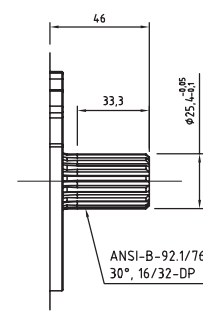

Type shaft SAEB-T15
Albero tipo SAEB-T15
Max torque / Coppia max: 700 Nm

GR72 - Group 5 tandem pumps

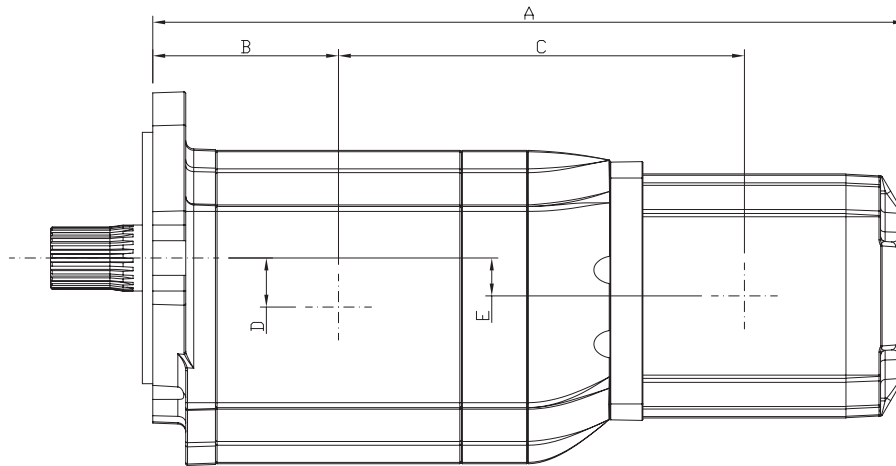

GR72 + GR47			2°					
			28	32	36	40	45	50
1°	94	A	440,00	444,00	448,00	452,00	456,50	461,50
		B	125,50	125,50	125,50	125,50	125,50	125,50
		C	232,00	234,00	236,00	238,00	240,25	242,75
		D	29,75	29,75	29,75	29,75	29,75	29,75
		E	19,50	19,50	19,50	19,50	19,50	19,50
	101	A	443,00	447,00	451,00	455,00	459,50	464,50
		B	127,00	127,00	127,00	127,00	127,00	127,00
		C	316,00	320,00	324,00	328,00	332,50	337,50
		D	29,75	29,75	29,75	29,75	29,75	29,75
		E	19,50	19,50	19,50	19,50	19,50	19,50
	125	A	453,00	457,00	461,00	465,00	469,50	474,50
		B	132,00	132,00	132,00	132,00	132,00	132,00
		C	238,50	240,50	242,50	244,50	246,75	249,25
		D	29,75	29,75	29,75	29,75	29,75	29,75
		E	19,50	19,50	19,50	19,50	19,50	19,50
	150	A	463,50	467,50	471,50	475,50	480,00	485,00
		B	137,25	137,25	137,25	137,25	137,25	137,25
		C	243,75	245,75	247,75	249,75	252,00	254,50
		D	29,75	29,75	29,75	29,75	29,75	29,75
		E	19,50	19,50	19,50	19,50	19,50	19,50
175	A	473,50	477,50	481,50	485,50	490,00	495,00	
	B	142,25	142,25	142,25	142,25	142,25	142,25	
	C	248,75	245,75	247,75	249,75	252,00	254,50	
	D	29,75	29,75	29,75	29,75	29,75	29,75	
	E	19,50	19,50	19,50	19,50	19,50	19,50	
200	A	484,00	488,00	492,00	496,00	500,50	505,50	
	B	147,50	147,50	147,50	147,50	147,50	147,50	
	C	254,00	256,00	258,00	260,00	262,25	264,75	
	D	29,75	29,75	29,75	29,75	29,75	29,75	
	E	19,50	19,50	19,50	19,50	19,50	19,50	

GR72 + GR55			2°			
			50	63	75	90
1°	94	A	468,00	477,00	485,00	496,00
		B	125,50	125,50	125,50	125,50
		C	246,00	250,50	254,50	260,00
		D	29,75	29,75	29,75	29,75
		E	19,50	19,50	19,50	19,50
	101	A	471,00	480,00	488,00	499,00
		B	127,00	127,00	127,00	127,00
		C	344,00	353,00	361,00	372,00
		D	29,75	29,75	29,75	29,75
		E	19,50	19,50	19,50	19,50
	125	A	481,00	490,00	498,00	509,00
		B	132,00	132,00	132,00	132,00
		C	252,50	257,00	261,00	266,50
		D	29,75	29,75	29,75	29,75
		E	19,50	19,50	19,50	19,50
	150	A	491,50	500,50	508,50	519,50
		B	137,25	137,25	137,25	137,25
		C	257,75	262,25	266,25	271,75
		D	29,75	29,75	29,75	29,75
		E	19,50	19,50	19,50	19,50
	175	A	501,50	510,50	518,50	529,50
		B	142,25	142,25	142,25	142,25
		C	262,75	267,25	271,25	276,75
		D	29,75	29,75	29,75	29,75
		E	19,50	19,50	19,50	19,50
200	A	512,00	521,00	529,00	540,00	
	B	147,50	147,50	147,50	147,50	
	C	268,00	272,50	276,50	282,00	
	D	29,75	29,75	29,75	29,75	
	E	19,50	19,50	19,50	19,50	

GR72 + GR72			2°					
			94	100	125	150	175	200
1°	94	A	556,50	-	-	-	-	-
		B	125,50	-	-	-	-	-
		C	311,50	-	-	-	-	-
		D	29,75	-	-	-	-	-
		E	29,75	-	-	-	-	-
	100	A	559,50	562,50	-	-	-	-
		B	127,00	127,00	-	-	-	-
		C	432,50	435,50	-	-	-	-
		D	29,75	29,75	-	-	-	-
		E	29,75	29,75	-	-	-	-

	125	A	569,50	572,50	582,50	-	-	-
		B	132,00	132,00	132,00	-	-	-
		C	318,00	319,50	324,50	-	-	-
		D	29,75	29,75	29,75	-	-	-
		E	29,75	29,75	29,75	-	-	-
	150	A	580,00	583,00	593,00	603,50	-	-
		B	137,25	137,25	137,25	137,25	-	-
		C	323,25	324,75	329,75	335,00	-	-
		D	29,75	29,75	29,75	29,75	-	-
		E	29,75	29,75	29,75	29,75	-	-
	175	A	590,00	593,00	603,00	613,50	623,50	-
		B	142,25	142,25	142,25	142,25	142,25	-
		C	328,25	329,75	334,75	340,00	345,00	-
		D	29,75	29,75	29,75	29,75	29,75	-
		E	29,75	29,75	29,75	29,75	29,75	-
	200	A	600,50	603,50	613,50	624,00	634,00	644,50
		B	147,50	147,50	147,50	147,50	147,50	147,50
		C	333,50	335,00	340,00	345,25	350,25	355,50
		D	29,75	29,75	29,75	29,75	29,75	29,75
		E	29,75	29,75	29,75	29,75	29,75	29,75

Available flanges and shafts for GR72
Flange ed alberi disponibili per GR72: SAED-23T

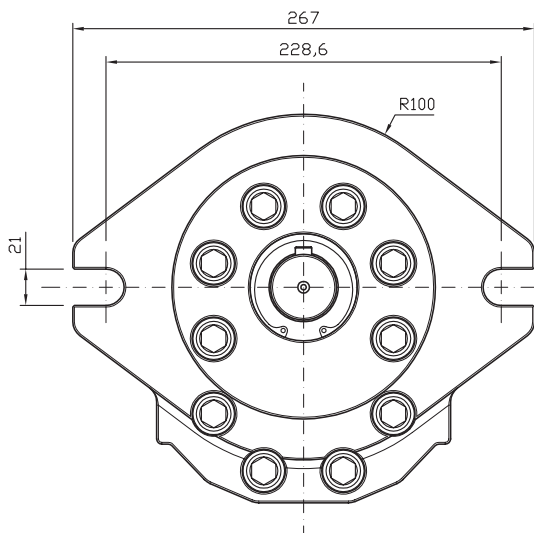

Type flange SAED-23T
 Flangia tipo SAED-23T

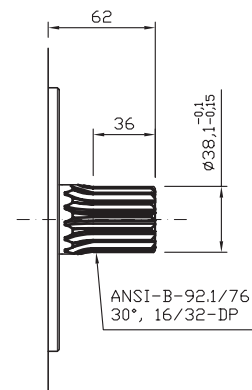
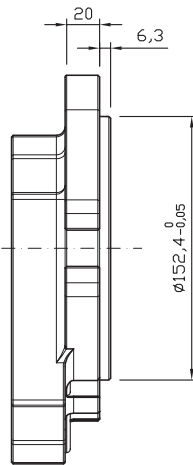

Type flange SAED-23T
 Flangia tipo SAED-23T
 Max torque / Coppia max: 1200 Nm

GR180 - Continuum® pump

Continuum® pump is a very flexible pump capable to meet the most different and demanding request of customization. Below an example of **Continuum®** pump designed and manufactured according to very special request for oil lubrication in the hydropower and power generation applications.

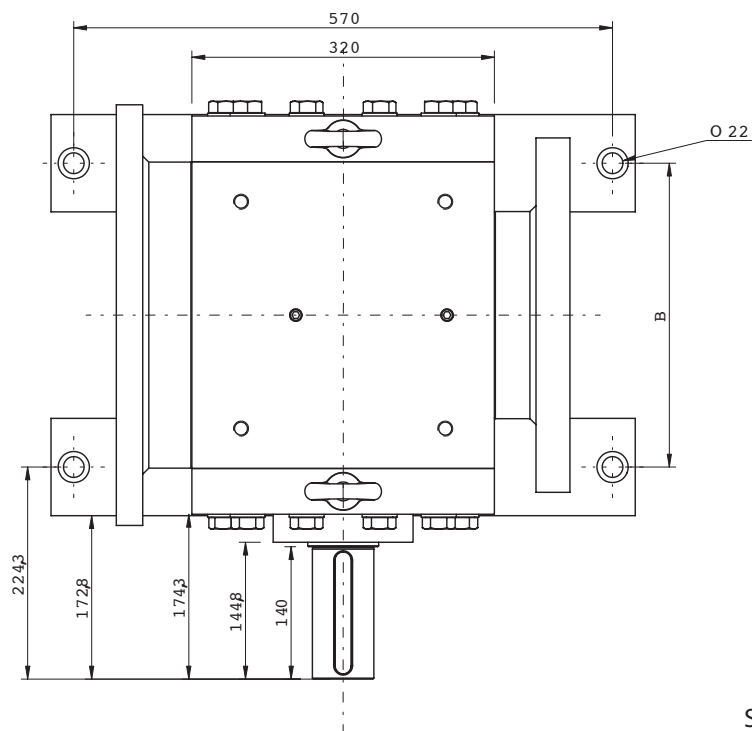
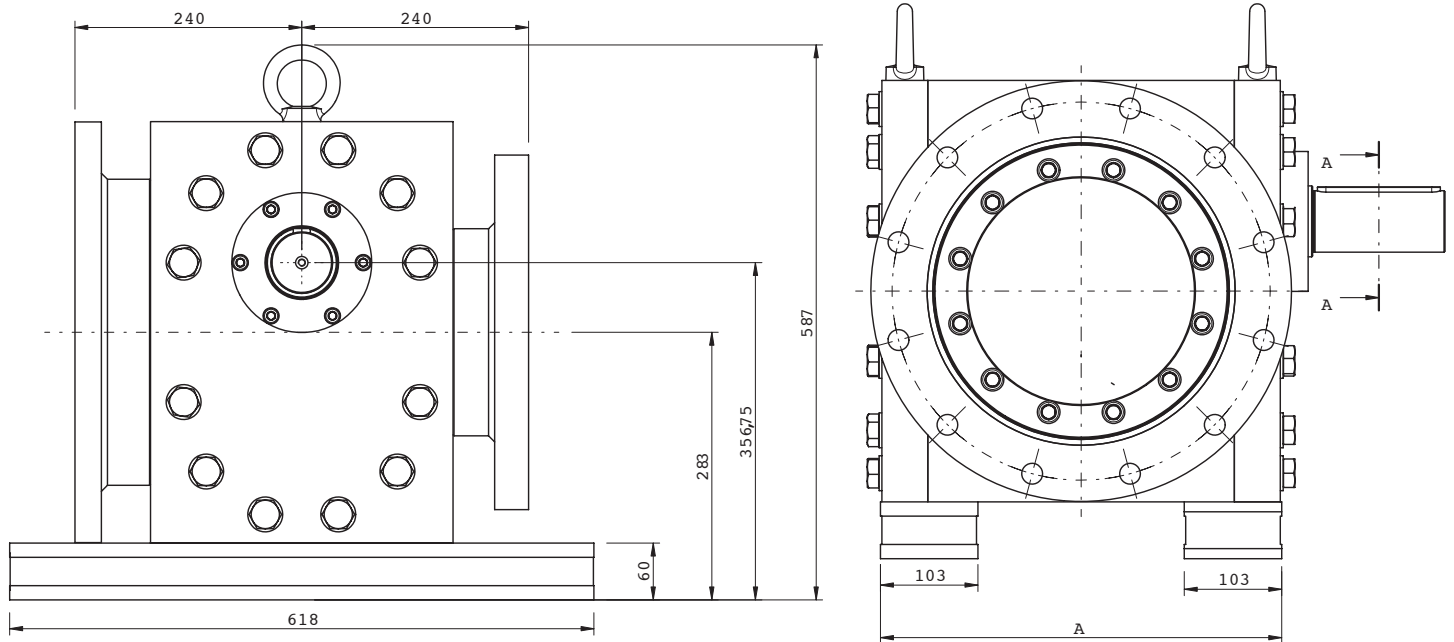

SECTION A-A

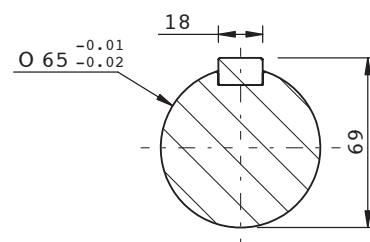

PUMP	A	B
GR180-2730cc	424,4 mm	321,4 mm
GR180-4100cc	516,4 mm	413,4 mm
GR180-4400cc	534,8 mm	431,8 mm

Technical characteristics

Models Modelli	GR180	
Displacements Cilindrate	2730cc - 4100cc - 4400cc	
Shaft speed Velocità di rotazione	Up to 1.500 RPM <i>Fino a 1.500 RPM</i>	
Flows Portate	Up to 6.000 L/min <i>Fino a 6.000 L/min</i>	
Operating pressure Pressione operativa	Up to 50 bar <i>Fino a 50 bar</i>	
Fluids Fluidi	- Mineral oil - Synthetic oil	- <i>Olio minerale</i> - <i>Olio sintetico</i>

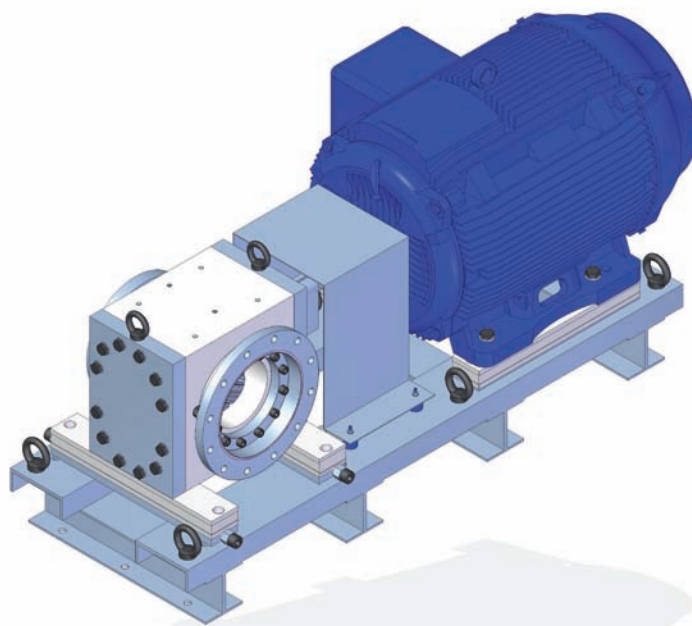
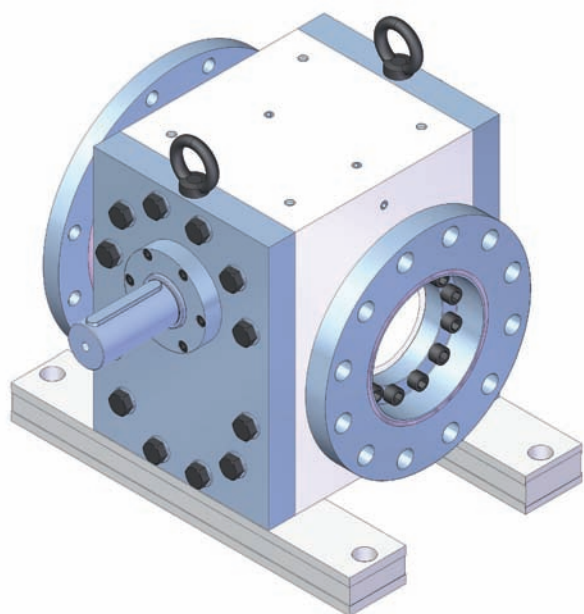

SETTIMA

Settima, Italy
Headquarter, r&d and production

SETTIMA

USA
Warehouse

SETTIMA

Shanghai, China
Warehouse



Settima Meccanica Srl
Settima - 29020 Piacenza (Italia)
tel. +39 0523.557623
fax +39 0523.557256
www.settima.it
info@settima.it



Area Agency/Reseller

Settima Flow Mechanisms
Settima - 29020 Piacenza (Italia)
tel. +39 0523.557623
fax +39 0523.557256
www.settima.it
info@settimafm.com

 **SETTIMA MECCANICA**

SETTIMA
flow mechanisms